

# ASXPRESS™

Rapid Sample Introduction Systems

Increase Throughput • Reduce Maintenance • Lower Costs

CETAC AUTOMATION



## Increase Throughput

- More sample throughput in less time by optimizing sample introduction
- Virtually eliminates stabilization time by removing the need for “fast pumping,” improving plasma stability

## Reduce Maintenance

- Extend the service life of ICP-AES/ICP-MS components such as nebulizers, spray chambers, and sample cones by reducing their exposure to the sample matrix

## Cost Effective

- Minimize sample consumption
- Reduce laboratory costs associated with argon and power consumption, peristaltic pump tubing replacement, and maintenance

## Simple Operation

- Easy set-up with minimal modification to the analysis method
- No additional complex software required; all system parameters are stored in the system’s on-board processor

## Data Quality

ICP data before and after ASXPRESS™ PLUS. The only difference between the runs is that half the time was saved using the ASXPRESS™ PLUS. Typical carryover has been measured at less than 0.1%.

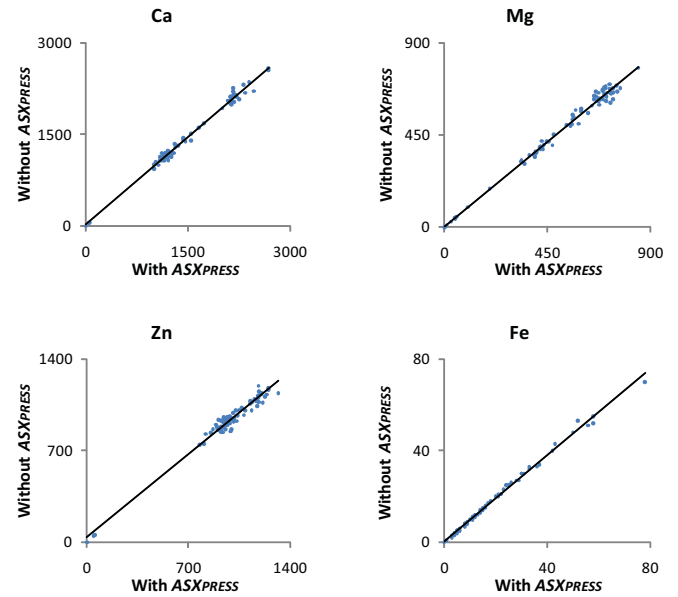

Data generated from oil sample analysis.

## Timing

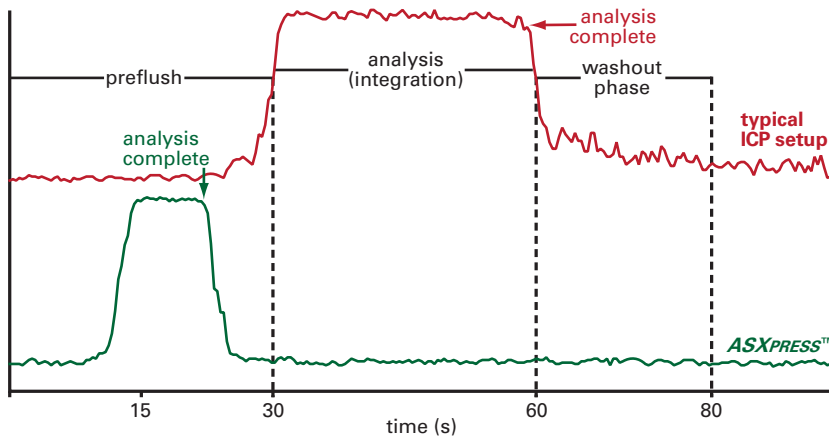

The ASXPRESS™ increases ICP-AES/ICP-MS analysis throughput by reducing sample delivery/rinse times without affecting measurement time. Multiple sample introduction steps occur simultaneously, resulting in virtual elimination of stabilization and rinse times.

### Typical Analysis Setup

Sample Introduction Step	Time Required
1. Autosampler Movement	5 sec.
2. Sample Uptake	15 sec.
3. Stabilization	20 sec.
4. Measurement	10 sec.
5. Rinse	30 sec.
<b>Total Time</b>	<b>80 sec.</b>

### ASXPRESS™ Analysis Setup

Sample Introduction Step	Time Required
1. Autosampler Movement, Sample Uptake, Stabilization, and Rinse	20 sec.
2. Measurement	10 sec.
<b>Total Time</b>	<b>30 sec.</b>

Use the online calculator at [www.cetac.com/automation/](http://www.cetac.com/automation/) to see how the ASXPRESS™ can save time and money.

## ASXPRESS™ Technology Description

The ASXPRESS™ Rapid Sample Introduction System increases sample throughput for ICP-AES and ICP-MS analysis by reducing sample loading, signal stabilization and washout times. Using proven technology, the ASXPRESS™ combines a metal-free, 6-port injection valve and inert, high-speed vacuum pump to rapidly load the sample loop for introduction to the nebulizer. The design of the ASXPRESS™ facilitates quickly rinsing the sample loop while simultaneously injecting sample into the ICP-AES or ICP-MS nebulizer for analysis. The segmented stream washout technology effectively cleans liquid flow paths more completely and in less time. The result is additional time dedicated to sample analysis, more effective flow path rinse, and reduced time between samples.

### System with Typical Setup

A standard analysis system relies upon a single peristaltic pump to both deliver samples to the nebulizer, and rinse the sample flow path between sample deliveries.

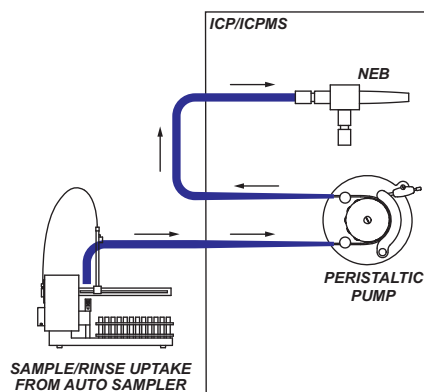

### System with ASXPRESS™ Technology

The ASXPRESS™ utilizes a high speed vacuum pump in addition to the ICP/ICP-MS peristaltic pump. The 6-port valve allows the use of both pumps simultaneously, as is illustrated below, reducing total sample analysis time significantly.

#### Load Position

The vacuum pump rapidly fills the sample loop (green path), while the ICP-AES or ICP-MS peristaltic pump simultaneously transports carrier solution, keeping the plasma stable (red path).

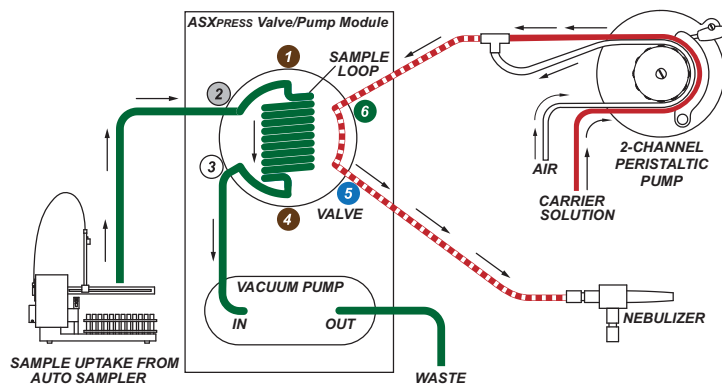

#### Inject/Rinse Position

The loaded sample is then pushed into the nebulizer for analysis via the carrier solution flowing through the ICP-AES or ICP-MS peristaltic pump (red/green path). Simultaneously, the autosampler probe is moved to the rinse station and the uptake flow path is flushed with rinse solution via the vacuum pump.

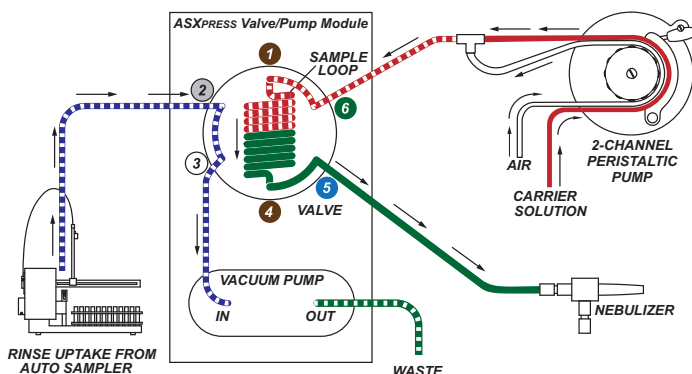

## ASXPRESS™ Technical Specifications

### Valve/Pump Module Dimensions:

**Height:** 12.8 cm (5.0")

**Width:** 5.8 cm (2.3")

**Depth:** 21.7 cm (8.5")

**Weight:** 1.30 kg (2.8 lb)



### Electronics Module Dimensions:

**Height:** 13.5 cm (5.3")

**Width:** 10.6 cm (4.2")

**Depth:** 12.8 cm (5.0")

**Hardware Interfaces:** 37-pin connector to autosampler

**Power:** 24 VDC (supplied by CETAC Autosampler)

**Warranty:** 2 year limited

## ASXPRESS™ PLUS Technical Specifications

### Valve/Pump Module Dimensions:

**Height:** 12.8 cm (5.0")

**Width:** 5.8 cm (2.3")

**Depth:** 21.7 cm (8.5")

**Weight:** 1.30 kg (2.8 lb)



### Electronics Module Dimensions:

**Height:** 25.4 cm (10.0")

**Width:** 8.3 cm (3.3")

**Depth:** 20.0 cm (7.9")

**Hardware Interfaces:** RS-232 to autosampler  
RS-232 and/or USB to host PC  
External pump connector

**Power:** 100-240 VAC ~ 47-63 Hz 1.9A

**Warranty:** 2 year limited

## Minimum Computer Requirements

Configuration tool requires Microsoft® Windows® 2000 or later release. No software is required for system operation.

ASXPRESS™ PLUS requires any combination of two RS-232 and/or USB communication ports.

## Autosampler Compatibility

ASXPRESS™	ASXPRESS™ PLUS
ASX-260	ASX-500
ASX-520	ASX-510
ASX-520HS	ASX-1400
EXR-8	ASX-1600
EXR-8HS	Non-CETAC autosamplers*

Either model may be purchased as a complete system along with choice of autosampler or as an upgrade to autosamplers already in operation.

\*Please contact CETAC for more information on the above listed autosamplers or in regards to operating an ASXPRESS™ system on non-CETAC autosamplers.

## Optional Accessories

### ASXPRESS™ Articulating Mounting System

Mounts to the ASXPRESS™ Valve/Pump Module to provide close proximity placement of the injection valve near difficult to reach nebulizers/spray chambers.

**Weight:** 3.072 kg (6.7 lb)

**Ordering Information:**  
SP6572



### Sample Load Loops

Sample load loops are available in multiple sizes for varying applications. Available sizes range from 0.5 mL to 5.25 mL. Please contact CETAC about additional sample load loop sizes.

**CETAC Automation**  
14306 Industrial Road  
Omaha, NE 68144 USA