

Sůl nad zlato a chemické prvky kolem nás
aneb
Stopová anorganická analýza pomocí AAS, ICP a ICP-MS

Pavel Janderka



Nové trendy v instrumentální analýze, 9.4.2015
Olomouc

Nebezpečný svět !?



Nejíst!

Nepít!

Nedýchat!





Sůl nad zlato trochu jinak!



- Potraviny a nápoje
- Suroviny pro výrobu potravin a nápojů
- Výrobní procesy
- Životní prostředí
- Zdravotnictví
- Odpady z domácností
- Odpady z těžby a průmyslové výroby
- Doprava
- ...

Kontaminanty ve všech fázích: *g, l, s*

Známe i z historie – např. otrava olovem, arzenem, rtutí ...



Typické detekční limity

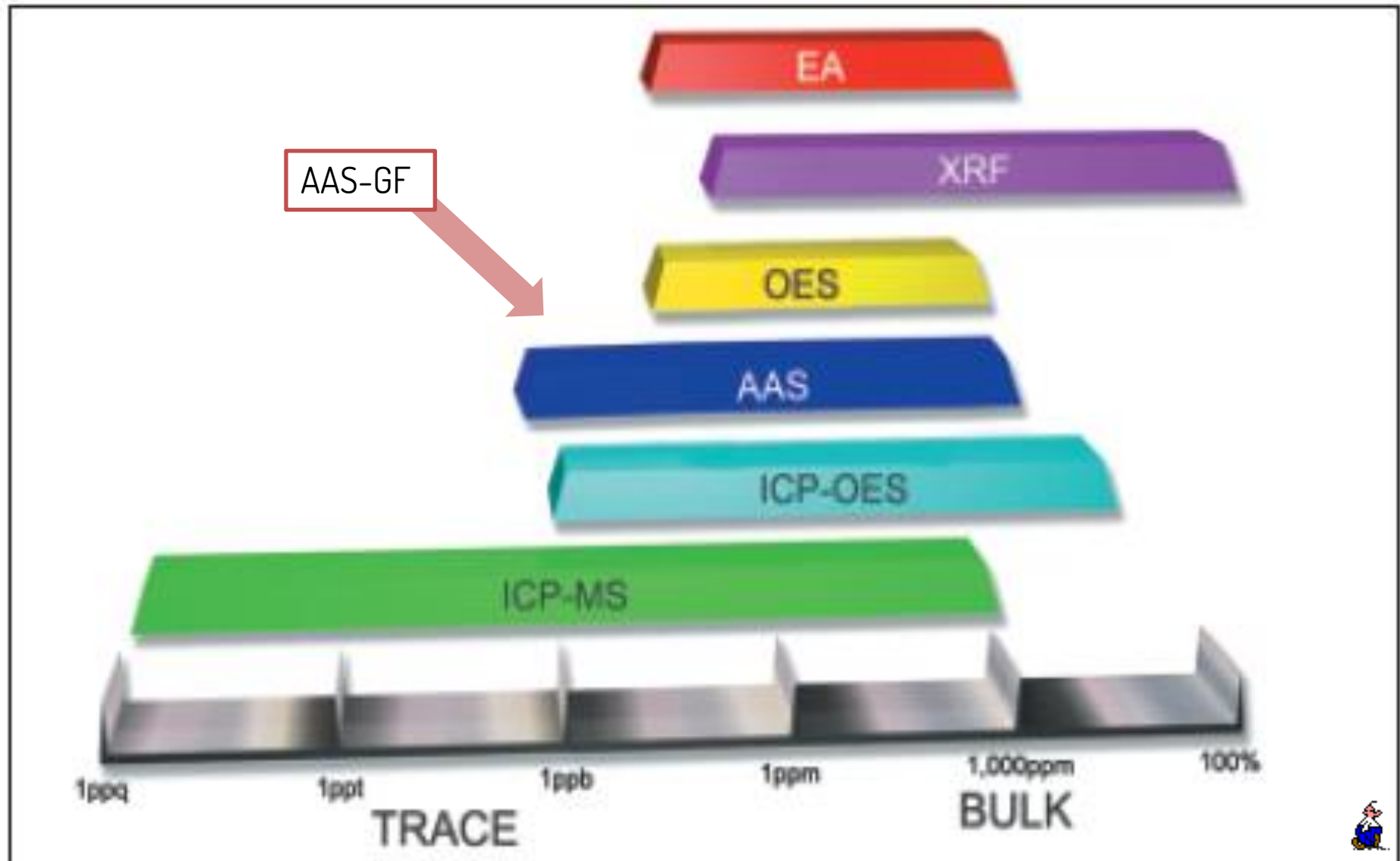

Analýza prvků v kapalných vzorcích...

Ne pevná fáze – LA-ICP, EDX, XPS/ESCA, Auger, SEM/TEM mikroanalýza – EDS/WDS/EBSD)

Technika	Objevena	Charakteristiky	Thermo Scientific
AAS	~1955	Jednoprvková analýza, ppb-ppm hladiny s plamenem nebo pecí, pro As, Se a Hg vhodné s generátorem hydridů	iCE 3000 Series
ICP-OES	~1972	Rychlá mnohoprvková analýza, ppb - % hladiny	iCAP 7000 Series
ICP-QMS	~1981	Rychlá mnohoprvková analýza, ppt-ppm hladiny	iCAP-Q Series
ICP-HRMS	~1987	Rychlá mnohoprvková analýza, ppq-ppm hladiny, bez interferencí	ELEMENT 2, XR, GD (Glow Discharge)



Porovnání analytického rozsahu



Jak tedy zvolit ten správný nástroj?

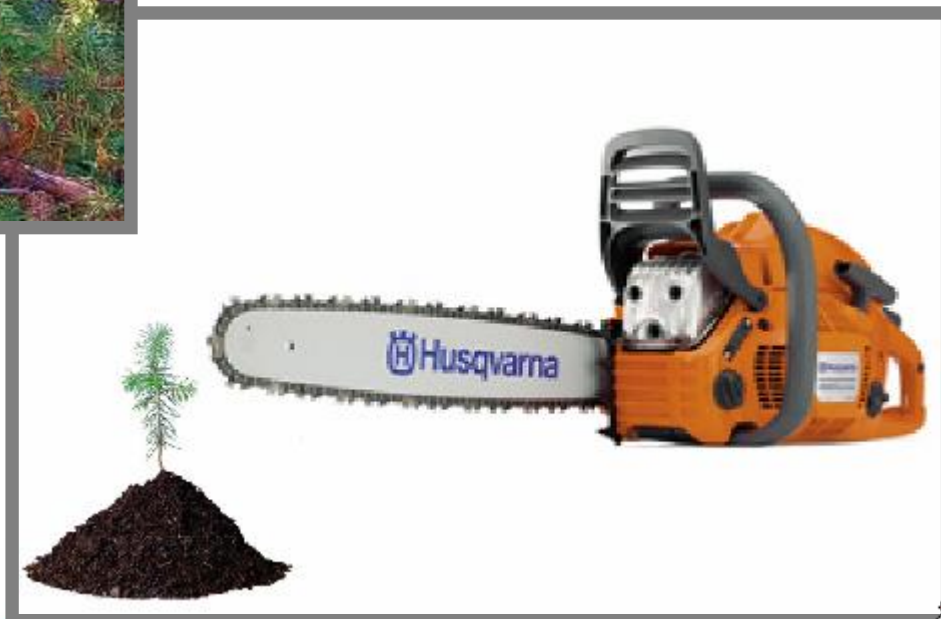

Thermo Scientific poskytuje kompletní portfolio zařízení!

Jednoelementové analýzy
nebo nízký počet vzorků

Multi-elementové analýzy

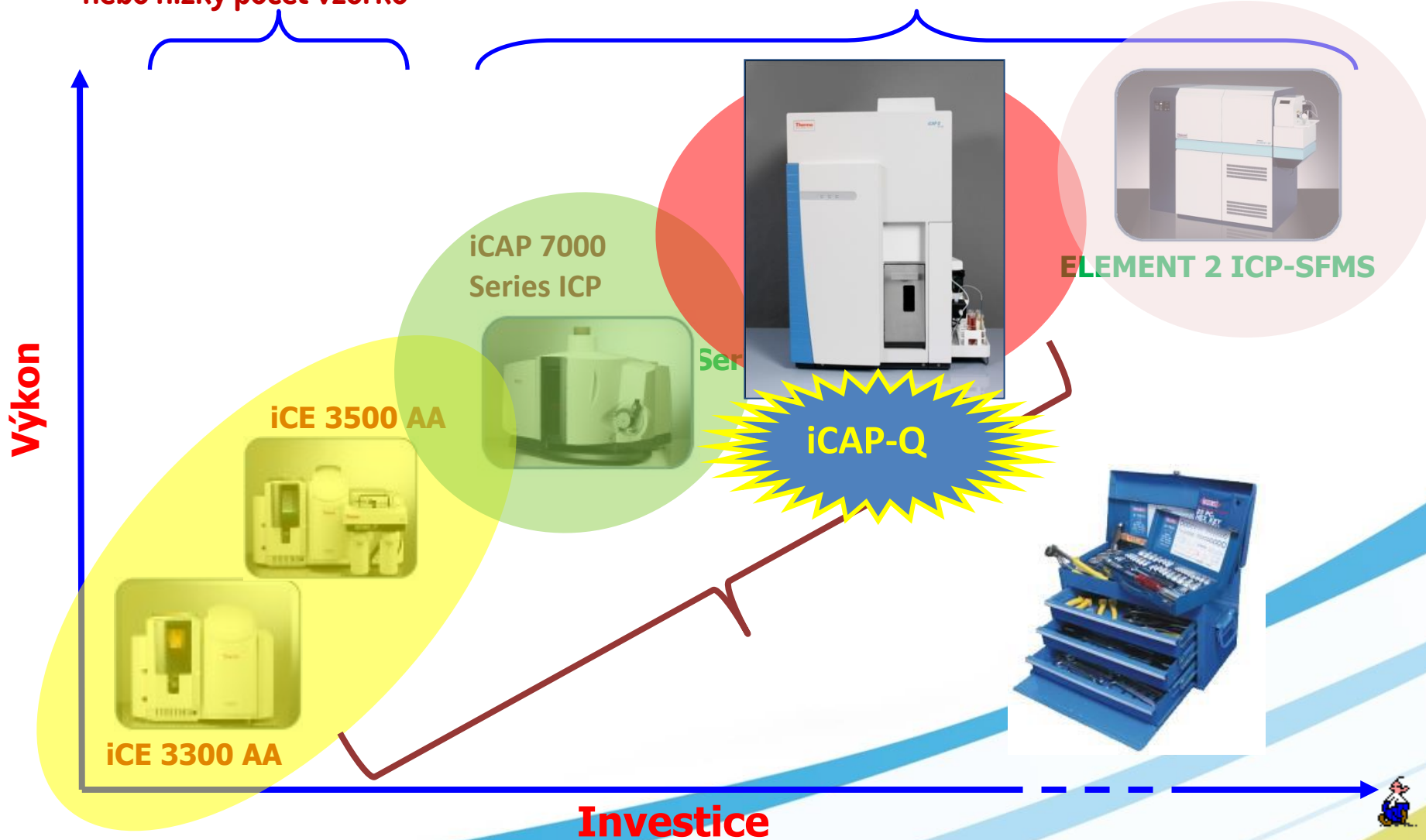

Kdo, Co a Proč

	Primární	Sekundární	Důvod 1	Důvod 2
ŽP - vody	ICP-MS	ICP/AA GF	DL	Rychlost
Farmacie	AA FI/GF	ICP-MS	Náklady	Málo vzorků
Použité oleje	ICP-OES	AA Flame	Rozsah prvků	Robustnost
Metalurgie	ICP-OES	AA FI/GF	Rozsah prvků	Náklady
Klinické lab.	AA FI/GF	ICP-MS	Povaha vzorků	Náklady
Geologie	ICP-MS	AA Flame	Povaha vzorků	Citlivost
Analýza potravin	AA FI/GF ICP-MS	ICP-OES	Náklady	Množství vzorků
Forensní	LA-ICP-MS	AA GF	Množství vzorku	Citlivost



Příklady použití AAS

Iron and Magnesium Determination in Meat using Flame Atomic Absorption Spectroscopy

Dr Anastasia Gadzhieva, AA Applications Chemist, Thermo Fisher Scientific, Cambridge, UK

Iron, Copper and Zinc Determination in Wine using Flame Atomic Absorption Spectroscopy

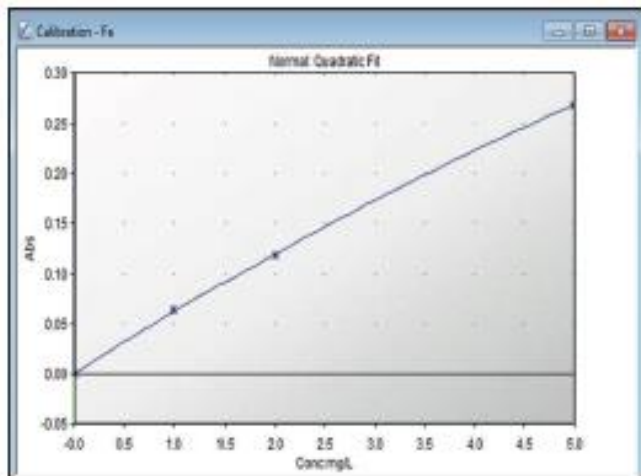

Figure 2: An example of a calibration curve for iron.

The results indicate that these meat samples do not exceed the recommended daily intake (RDI) of 15 mg/kg for iron and 350 mg/kg for magnesium.



In vino veritas, in aqua sanitas.

(Ve víně je pravda, ve vodě je zdraví)

Table 1. Instrument settings for the ICE 3300 AAS.

Parameter	Iron	Copper	Zinc
Wavelength	248.3 nm	324.8 nm	213.9 nm
Band pass	0.2 nm	0.5 nm	0.2 nm
Background Correction	D2	D2	D2
Lamp Current	75%	75%	75%
Signal	Continuous	Continuous	Continuous
Flame type	Air-Acetylene	Air-Acetylene	Air-Acetylene
Fuel flow rate	0.9 L/min	1.1 L/min	1.2 L/min
Measurement Time	4s	4s	4s
Replicates	3	3	3

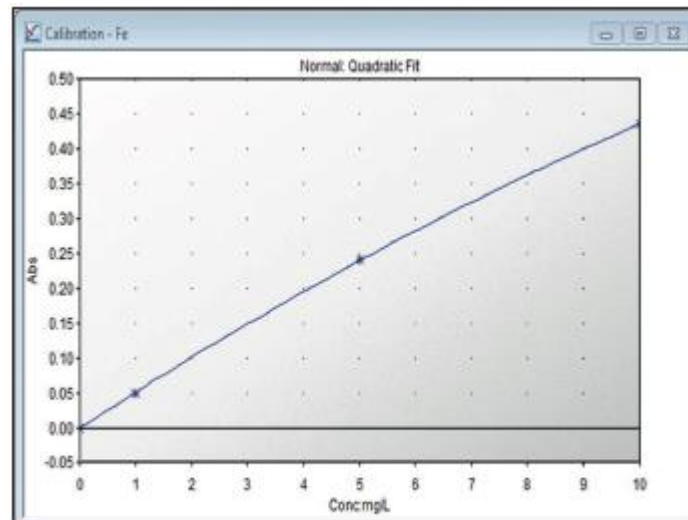

Figure 2: Calibration curve for Iron.

*All data was calculated from 3 replicate readings for each solution, the results are calculated with a view of 1:4 dilution.

Sample ID	Iron (mg/L)	Copper (mg/L)	Zinc (mg/L)
White wine*	1.165	0.027	0.988
Rosé wine*	1.835	0.028	0.514
Red wine*	2.437	0.037	0.575



Cadmium Determination in Crab Meat using Graphite Furnace Atomic Absorption Spectroscopy

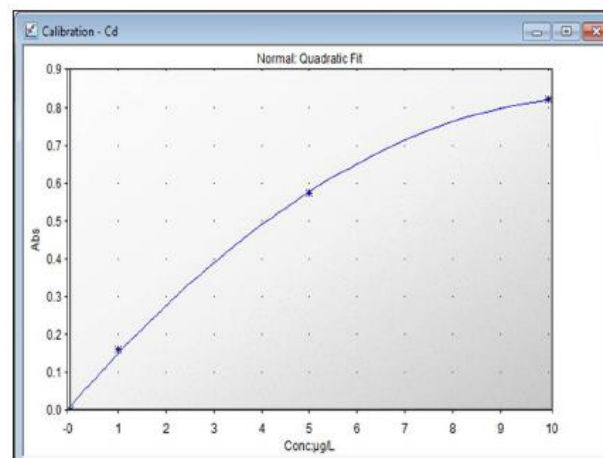

Figure 3: The calibration curve for cadmium.

Table 3. Results show the measured concentration of cadmium as well as expected and measured concentrations with percentage spike recovery for three separate crab samples (*all data was calculated from 3 replicate readings for each solution using transient peak height measurements).

Sample	Measured concentration sample (mg/kg)	Expected concentration spike (mg/kg)	Measured concentration spike (mg/kg)	Spike recovery (%)
Tinned crab*	0.0005	0.5005	0.4663	93.2
Dressed crab*	0.9641	1.46	1.4594	100.0
Crab pâté*	0.6143	1.06	1.0919	103.0



Další příklady

Food Safety Series – Accurate analysis of low levels of mercury in fish by vapor generation AA



The Analysis of Cadmium in Chocolate by Graphite Furnace Atomic Absorption Spectrometry



The Determination of Selenium in Shampoo by Flame Atomic Absorption Spectrometry



Determination of Trace Elements in Rice Products by Flame and Graphite Furnace Atomic Absorption Spectrometry

Rebecca Price, Thermo Fisher Scientific, Cambridge, UK

Application Notes 43019

Method Guide: 40184

Atomic Absorption Full Method Sn in Canned Fruit Juice

The Analysis of Trace Elements in Honey by Flame and Graphite Furnace Atomic Absorption Spectrometry

Rebecca Price, Thermo Fisher Scientific, Cambridge, UK

Application Notes 43060

Key Words

Atomic Absorption, Esse Rice, Toxic Elements.

Key

- Th
- Ab
- cap
- per
- An
- pr
- me
- Th
- all
- fur

Sum

The Spectrometer Flame tool is equipped with atom detector, optical

Intr

Rice with 600 count between crop essence of health cadmium Prefe

Key Words

Atomic Absorption, Flame, Deuterium, Graphite Furnace, Honey, Zeeman

Key Benefits

- The robust flame sample introduction system allows dissolved honey samples to be run without blockage or contamination.
- The advanced furnace autosampler speeds up analysis by automatically preparing the working standards from a single master standard.
- The permanently aligned true dual atomizer enables rapid switching between flame and furnace methods.
- Deuterium and Zeeman background correction offer a flexible solution for the analysis of challenging matrices such as honey.

Summary

The Thermo Scientific iCE 3500 Atomic Absorption Spectrometer is the ideal solution for the analysis of major, minor and toxic elements in honey. The permanently aligned true dual atomizer allows robust and reliable analysis of major elements by flame, followed by accurate and precise determination of minor and toxic elements by graphite furnace.

Introduction

Honey is a sweet and viscous substance produced from the nectar and secretions of plants and flowers. The nectar is transported to a beehive by honey bees, where worker bees then add enzymes to create honey. Most honey is created from a variety of plants and flowers, though in some areas, where a particular plant or flower is in abundance, monofloral honey can be produced, and this is particularly valuable. Honey is typically advertised to the consumer by floral source or geographical location, however many honey products are blended from a variety of sources. This has resulted in a global market with hundreds of types of honey, each with unique taste, color and crystallization properties. In the EU, honey must adhere to strict composition criteria, including sugar, moisture and hydroxymethylfurfural (HMF) content.¹

Analysis of Zinc in Toothpaste using the Thermo Scientific iCE 3000 series AAS

Bhagwesh Sunkar, Dr. G. W. Joshi, Dr. B.A. Patra and Rakesh Jha, Thermo Fisher Scientific, Mumbai, India

Application Note 43139

Key Words

AA, Flame, Teeth, Toothpaste, Zinc

Introduction

Typically our day starts with a mixture of chemicals, toothpaste, a paste or gel dentifrice used with a toothbrush as an accessory to clean and maintain the aesthetics and health of teeth. Toothpaste is used to promote oral hygiene: it serves as an abrasive that aids in removing the dental plaque and food from the teeth, assists in suppressing halitosis (bad breath), and delivers active ingredients such as fluoride or xylitol which help to prevent tooth and gum disease (gingivitis).¹⁾

Although toothpaste was used as long ago as 500 BC in ancient Egypt, China and India, it was not until the 19th century that toothpastes came into general use. Ancient tooth powders used abrasive ingredients such as crushed bone, burned and crushed egg, snail or oyster shells, which were used to clean debris from teeth. First 'modern' toothpastes in the 1800s were homemade, with chalk, soap and salt as common ingredients and were sold in jars either as a powder or paste. A dentist in the US first introduced tooth paste in a tube, in 1892. The most important breakthrough in the history of toothpaste was the addition of fluoride in toothpaste in 1914. The use of fluoride in toothpastes became widespread much later in the 1950s.

Modern toothpaste is a complex formulation that has many more added ingredients since it was first introduced. Extensive work has been carried out to introduce an ingredient which can provide effective protection against various dental conditions.

Triclosan is reported as one of the commonly used important antimicrobial agents used in toothpaste that fight the bacteria which contribute to dental plaque. However, Triclosan induces damage and lesions to the cell wall of bacteria resulting in bacteriolysis (death of the cell) and hence its use is restricted or banned in many countries.²⁾



As an alternative to Triclosan many leading manufacturers prefer to use bacteriostatic agents such as zinc (zinc chloride or zinc citrate) which stop the growth of dental plaque bacteria by inhibiting their metabolism. The combination of bacteriostatic and bactericidal agents as toothpaste ingredients is the most effective one way to fight dental plaque and gum disease.

This application note presents a simple, rugged flame atomic absorption spectrometry method for the analysis of zinc in toothpaste. Random samples of known international & local brands in the market were used for this work.

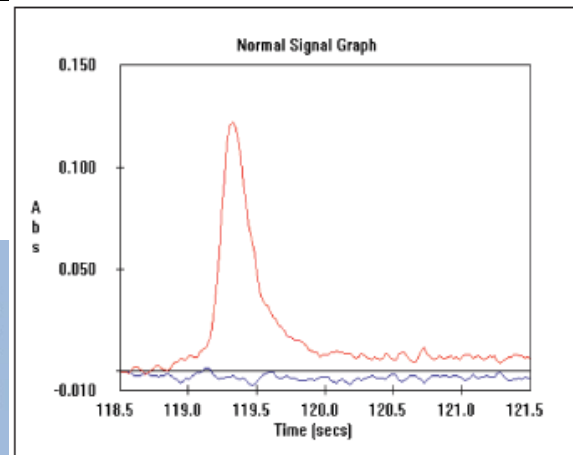

Figure 3: Correction with QuadLine background correction

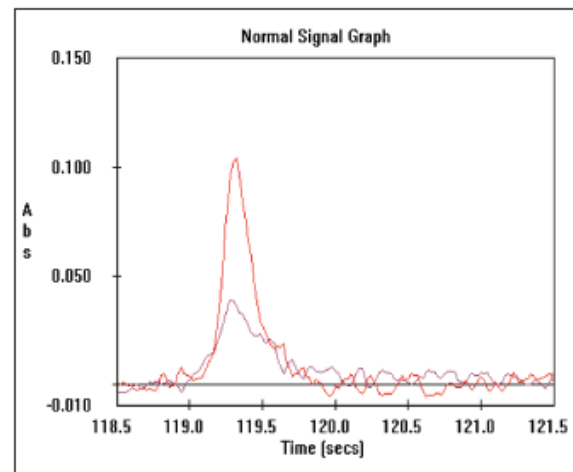

Figure 4: Correction with Zeeman background correction

Thermo SCIENTIFIC



The Analysis of Clinical Samples by Atomic Absorption Spectrometry



Krev a sérum

moč



3) Analytes:

The metallic elements measured in clinical analyses fall into three groups according to their role in human metabolism, and they are usually classed as essential, toxic or therapeutic.

Essential elements

- Essential major elements:
Ca, Mg, Na, K
- Essential minor elements:
Zn, Cu, Fe
- Essential trace elements:
Cr, Mn, Mo, Co, V, Se, Ni



Shrnutí

Malý počet vzorků, single-element analýzy	AA
Vysoký počet vzorků na multi-element analýzy	ICP ICP-MS
Nízké detekční limity	ICP-MS ICP
'Špinavé' vzorky	ICP AA
Rozklady se střední koncentrací a vysokým pozadím	ICP ICP-MS
'Čisté' vzorky, nízké koncentrace	ICP-MS
Velmi nízké koncentrace, komplikované matrice	ICP-SFMS (nebo CRC)



Jak tedy zvolit ten správný nástroj?



TECHNICKÉ PARAMETRY



Technické vlastnosti - AAS

Některá klíčová slova při diskusích

„Mýty a nepravdy“

- AAS: zdroj světla – standardní lampy – kontinuální zdroj světla, „**superlampy**“, „**boosted**“ lampy, „**dusíková plazma**“,
- GF-AAS: **longitudální** nebo **trasverzální** uspořádání,
- Korekce pozadí: D_2 – Zeemanova kor., – **Pulzní**,
- „**Sekvenční**“ vs. „Standardní“ víceprvkové měření, u FI-AAS.
- Nároky na údržbu – provozní nákladovost.



Některá klíčová slova při diskusích

- Technické vlastnosti – ICP-OES
- Optické rozlišení, spektrální rozsah „Alkal. kovy->nekovy“,
- Dostupnost „spektrálních oblastí“, pohled na plazmu
- Uspořádání vnášecího systému a plazmové hlavice – rozebiratelnost ...,
- RF generátor (frekvence, konstrukce, účinnost, stabilita, nastavení ...,
- Typ a konstrukce detektoru, možnost „Full Frame“,
- Celková stabilita plazmového a optického systému.
- Nároky na údržbu – nákladovost.



Výběr nástroje od NÁS je na VÁS...

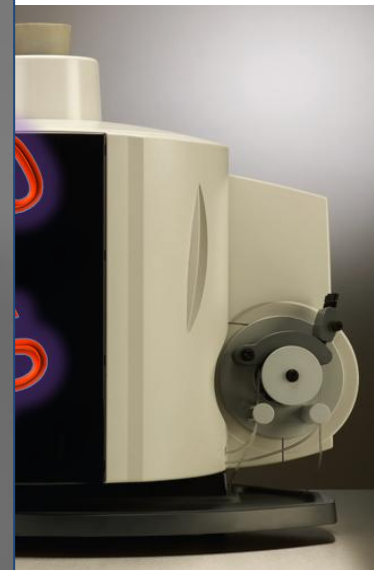

ICP-OES (iCAP 7000)

NEW



low cost
ICP-OES analysis

Děkují za pozornost

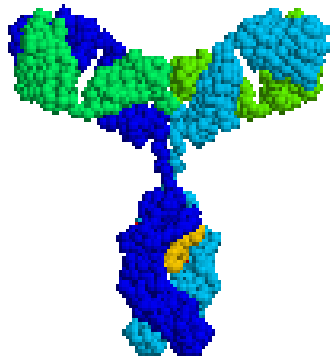

JANDERKA@PRAGOLAB.CZ

Některá klíčová slova při diskusích

- Technické vlastnosti – ICP-MS-Q (TOF)
- Citlivost (cps/ppb) a jak je to s pozadím „S/N“, (<1cps)
- Konstrukce iontové optiky (kóny – odstranění nežádoucích částic – kolizní-reakční optika a prvkové interference,
- Analyzátor (Kvadrupól, frekvence) – detektor (analogový i digitální) – rozsah linearity – rychlost skenování.
- Tzv. triple-Q vs. Single-Q,
- RF generátor (frekvence), konstrukce, účinnost, stabilita, nastavení ...,
- Nároky na údržbu – nákladovost, pracnost, periodičita.



ICP-MS

ICP-QMS spektrometr iCAP Q - Novinka 2012
2013 oceněno cenou za inovativnost

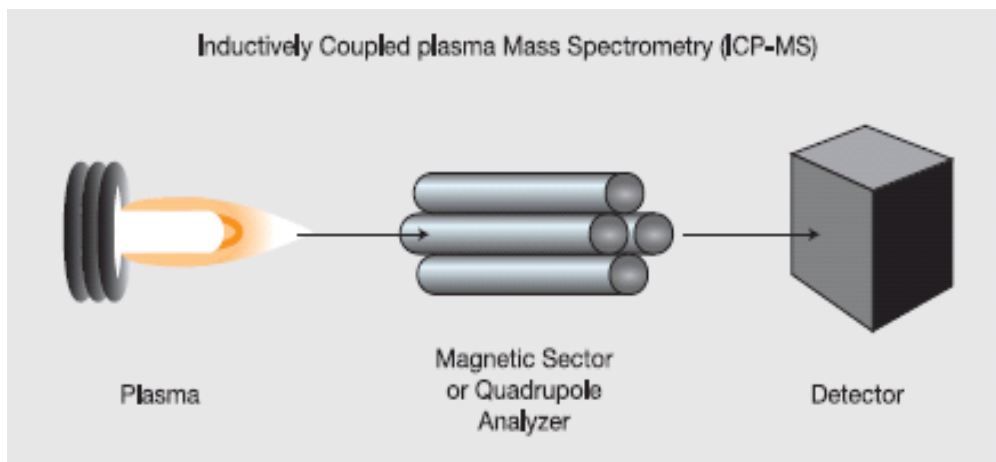

iCAP Q bez „kapoty“

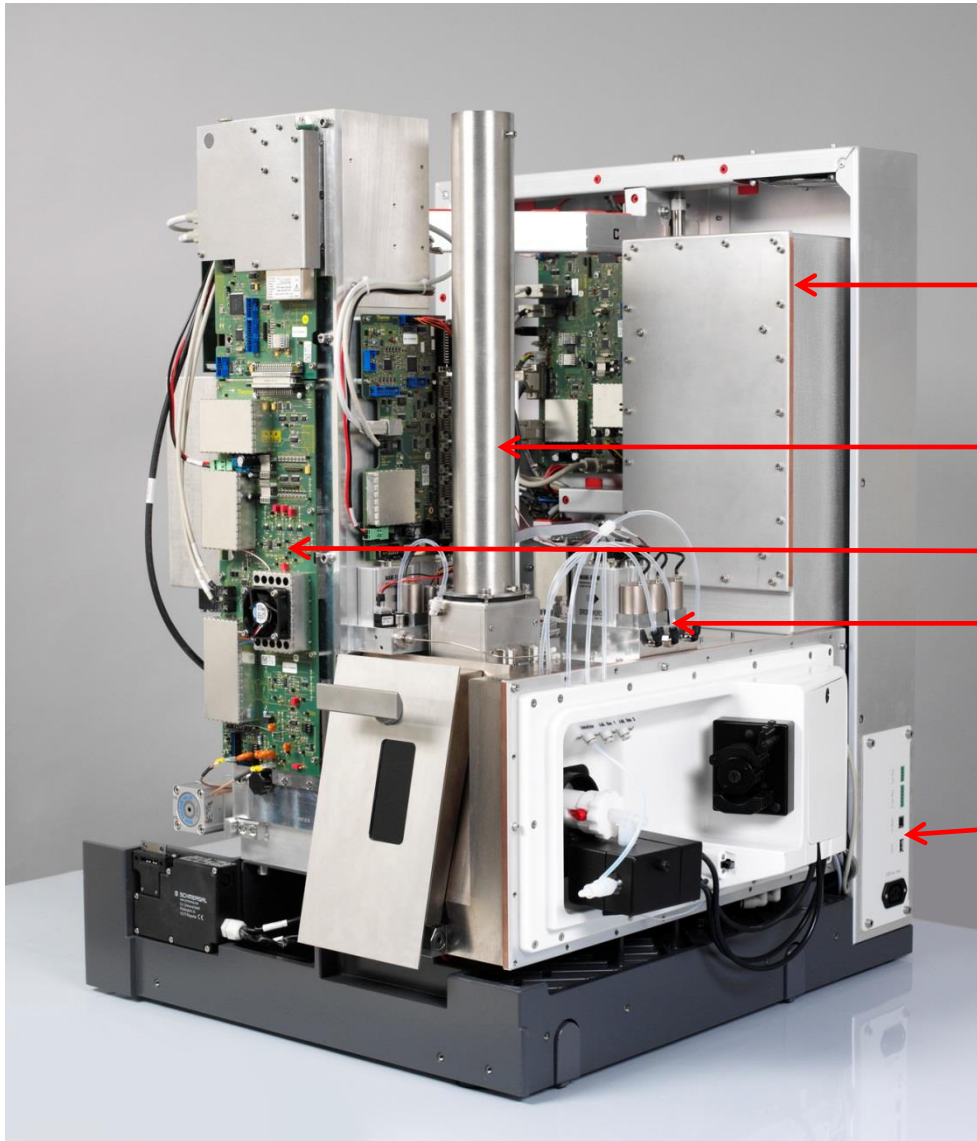

RF Generátor
plazmy, 27 MHz

Odtah plazmy

Deska elektroniky

Mass Flow Controller

USB, Digital I/O

Co je nového na novém ICP-MS?

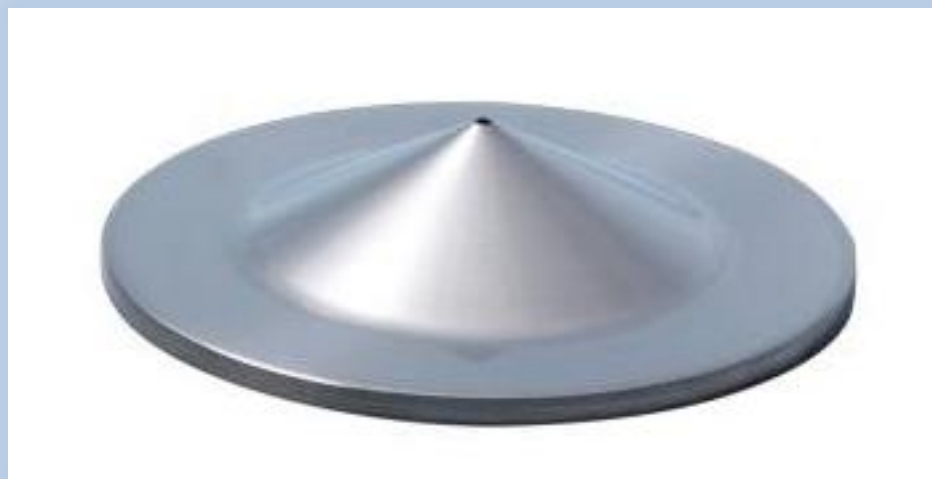

Pouze „sample cone“ je použit z XSeries2
Vše „ostatní“ je NOVÉ

Produktová linie ICP-MS od Thermo Scientific

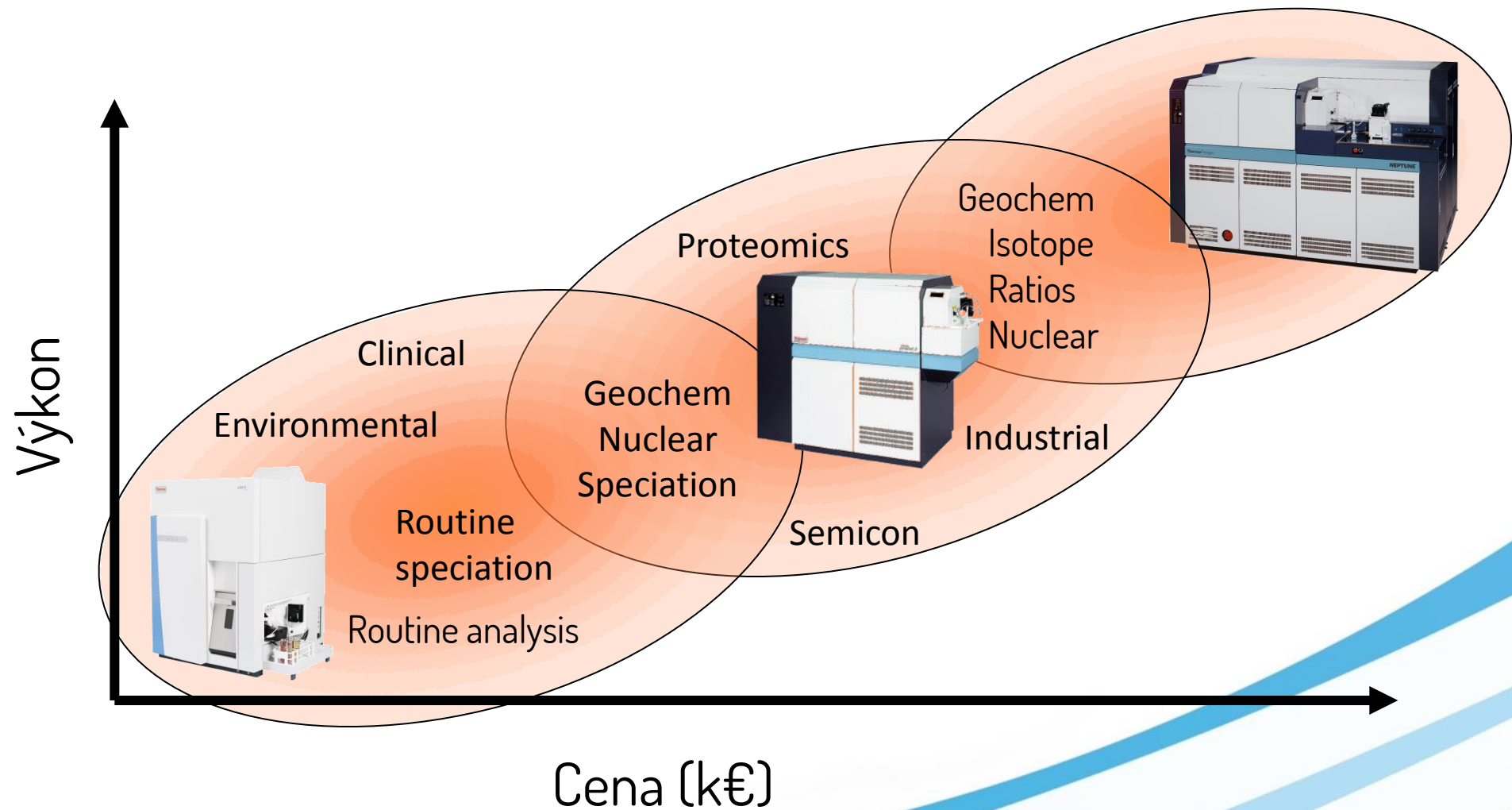

Koncepce iCAP Q

- Robustní, dokonalý analytický výkon v kategorii Q-MS,
- Nízké provozní náklady,
- Minimální instalační nároky
- Minimální provozní údržba
- Maximální jednoduchost těch údržbových úkonů, které jsou doporučené ,
- Intuitivní, ale výkonná SW platforma **Qtegra**
- Flexibilita - pro rutinní analytický provoz 24/7 i pro výzkum a pokročilé metody (Laserová ablace, speciace LC/GC/IC) s plnou integrací všech zařízení v prostředí **SW Qtegra**

iCAP Q ICP-MS: Simplified installation

Nízko údržbové
provedení

Přístroj lze nainstalovat
zcela ke zdi, není nutný
žádný zadní servisní
přístup

Veškerý servis jen
zepředu a z boku



Všechna servisní
připojení jsou na
boku přístroje

System zavádění vzorku iCAP Q

- Čtyřkanálová peristaltická pumpa s miniválečky s nízkým pulzováním vzorku
- Peltierovsky chlazená zmlžovací komora, $t_{\min} -10^{\circ}\text{C}$
- Cyclonická zmlžovací komora umístěná těsně k plazmové hlavici
- Snadný přístup k MFC



Intuitive Quick-Connect Sample Introduction Components

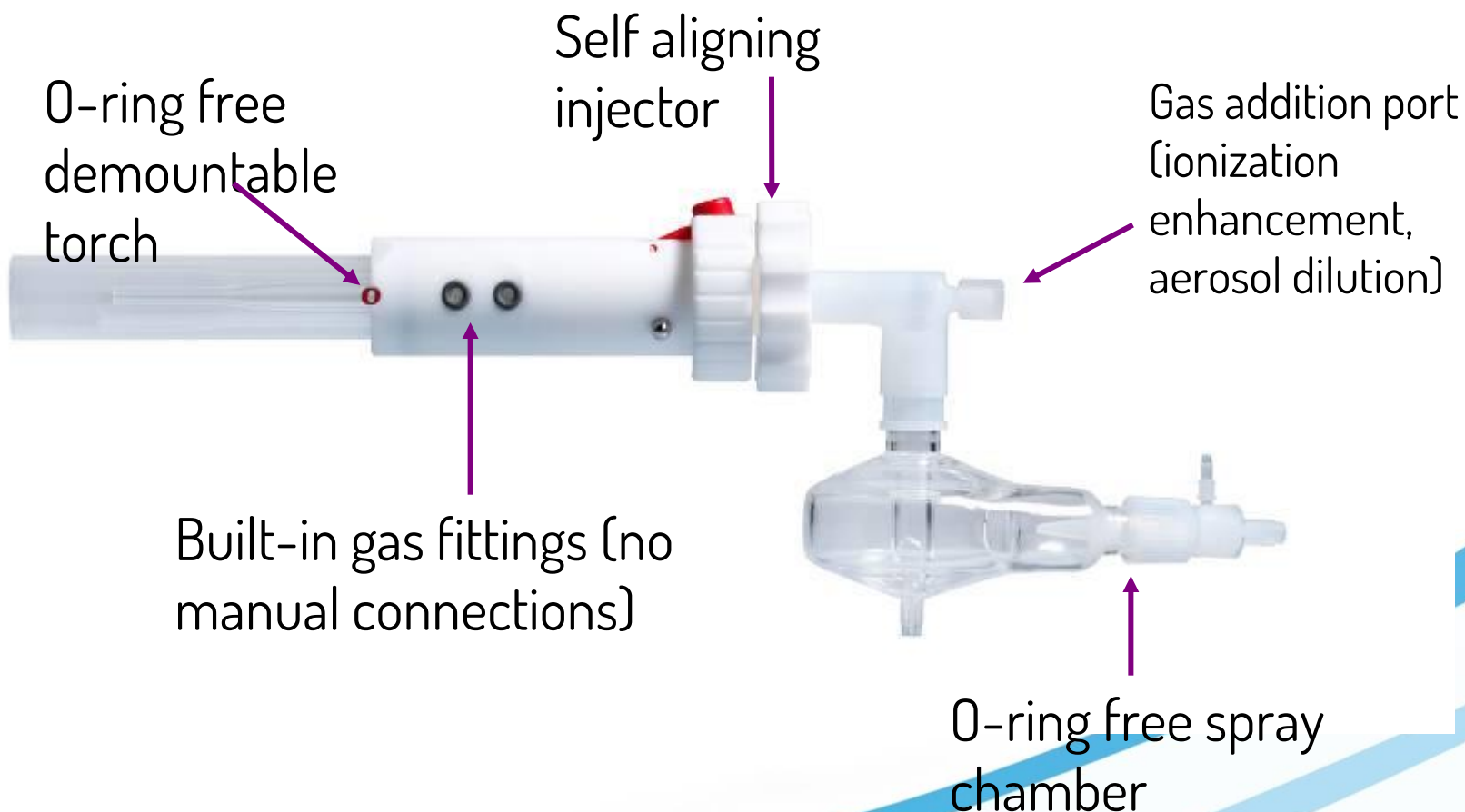

Jednoduše demontovatelná plazmová hlavice



iCAP Q – Overview + Nový SW Qtegra

Nový A+D detektor

Nová elektronika a SW

Nová kolizně-reakční cela (QCell) vylepšený přenos iontů a rychlejší přepínání měřících módů

RAPID Lens – 90° deflekcce neutrálních částic a molekul plynu

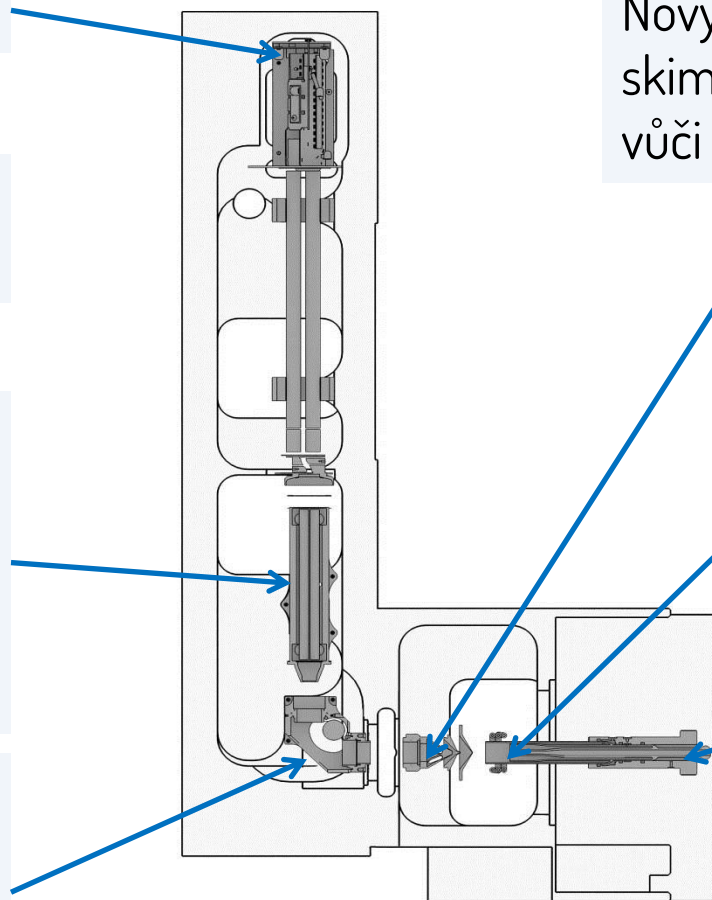

Nový interface vč. nového skimmer kónu – zvýšená odolnost vůči matrici a snadná údržba

iCAP RF generátor nevyžaduje stínění plazmy

Nové provedení plazmové hlavice – snadná manipulace



Plasma TV: „Live“ pohled a sledování plazmy integrovanou video kamerou

Užitečné pro Optimalizaci plazmy, (např. O_2 pro organická rozpouštědla)

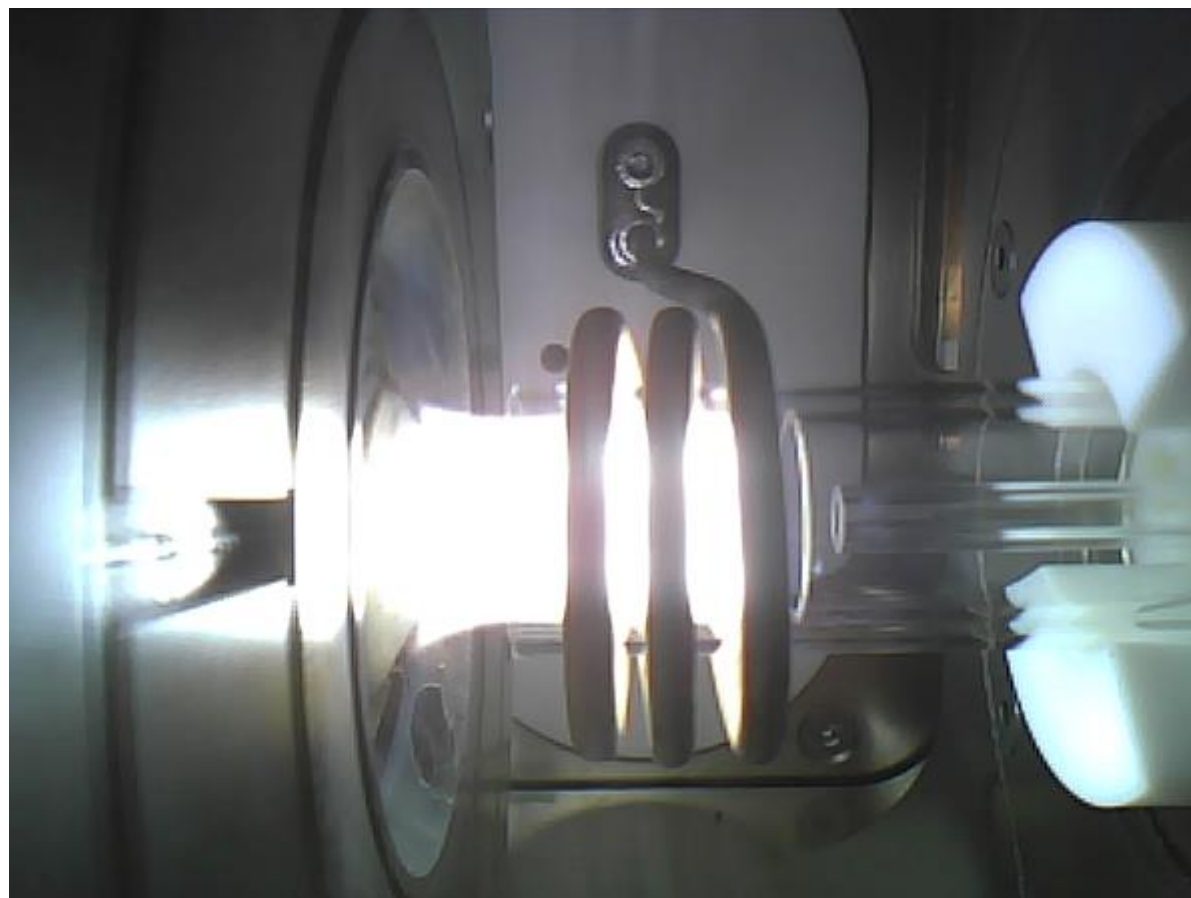

Možnost rychlé „diagnózy“ např. u vzorků s vysokým podílem rozpuštěných složek)



iCAP Q - Modely

Product		iCAP Qa	iCAP Qc	iCAP Qs
				
Sensitivity [kcps/ppb]	⁷ Li	40	50	80
STD Mode	¹¹⁵ In	150	220	400
	²³⁸ U	200	300	500
Sensitivity [kcps/ppb]	⁵⁹ Co	-	30	50
KED Mode				
Oxides [%]	CeO/Ce	< 2	< 2	< 2
Doubly Charged [%]	Ba ⁺⁺ /Ba ⁺	< 3	< 3	< 3
Background m/z 4.5 [cps]	STD	< 1	< 1	< 1
	KED	-	< 0.5	< 0.5

iCAP Q - Modely

Product	iCAP Qa	iCAP Qc	iCAP Qs
			
Short Term Stability (10 min) [%]	< 2	< 2	< 2
Long Term Stability (2 h) [%]	< 3	< 3	< 3
Detection Limits [ppt]			
⁹ Be	< 0.5	< 0.5	< 0.5
¹¹⁵ In	< 0.1	< 0.1	< 0.1
²⁰⁹ Bi	< 0.1	< 0.1	< 0.1
Isotope Ratio Precision [%RSD]			
¹⁰⁷ Ag/ ¹⁰⁹ Ag	< 0.1	< 0.1	< 0.1

Dramatically Different Ion Focusing:

RAPIDLens

Right

Angle

Positive

Ion

Deflection

90° totální iontová
fokusace s deflexí ve 3D

a

Eliminace neutrálních částic

pro

dosažení nejvyššího poměru
S/N ve třídě Q-ICP-MS

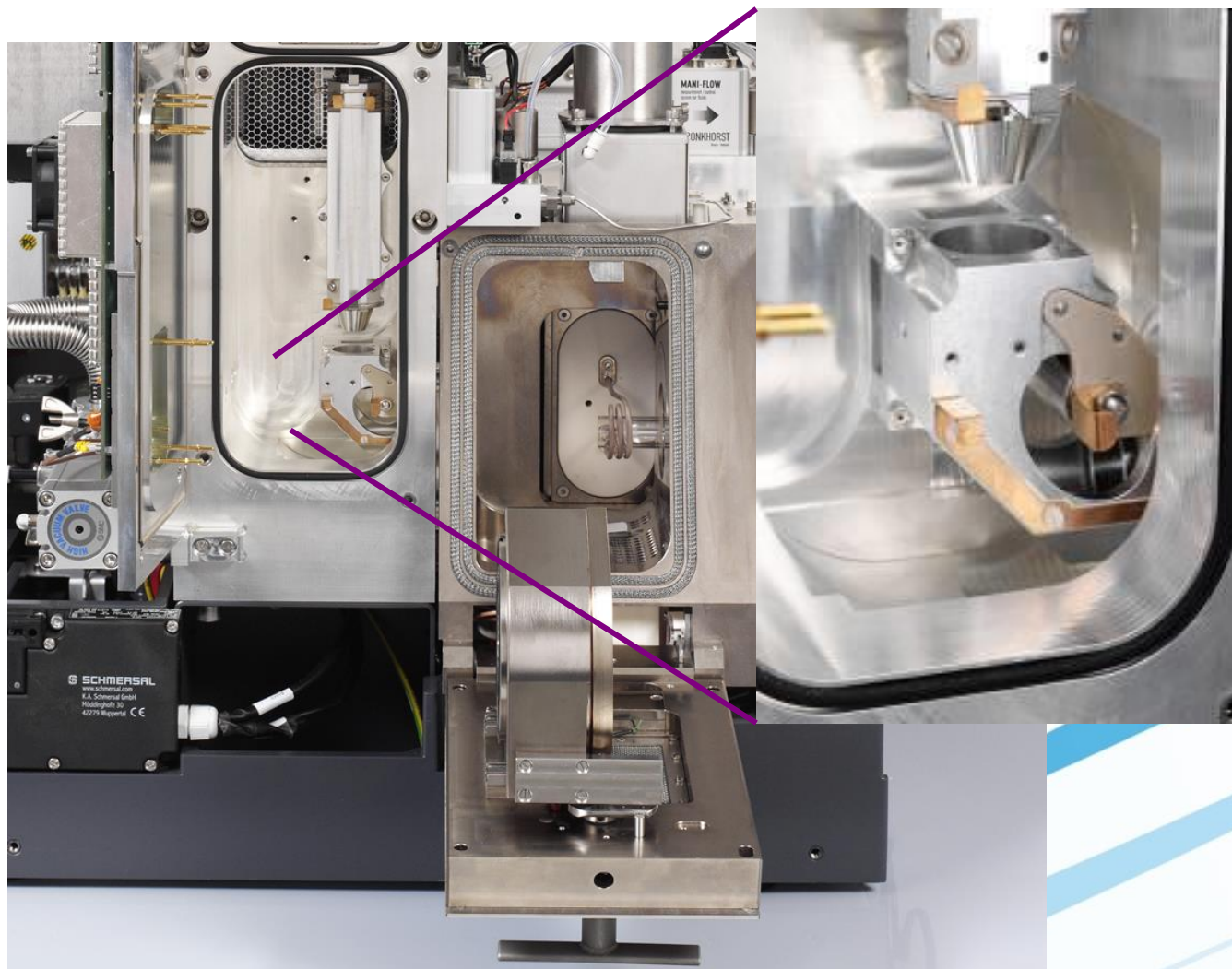

RAPID Lens – Simplicity and ion optics done right

- “Jednoduché” provedení ze 3 částí:
 - Vstupní a výstupní čočky
 - Deflekční čočky mezi nimi
- Jednoduché ovládání pomocí vložení napětí
- Optimální deflexe iontů a fokusovací vlastnosti

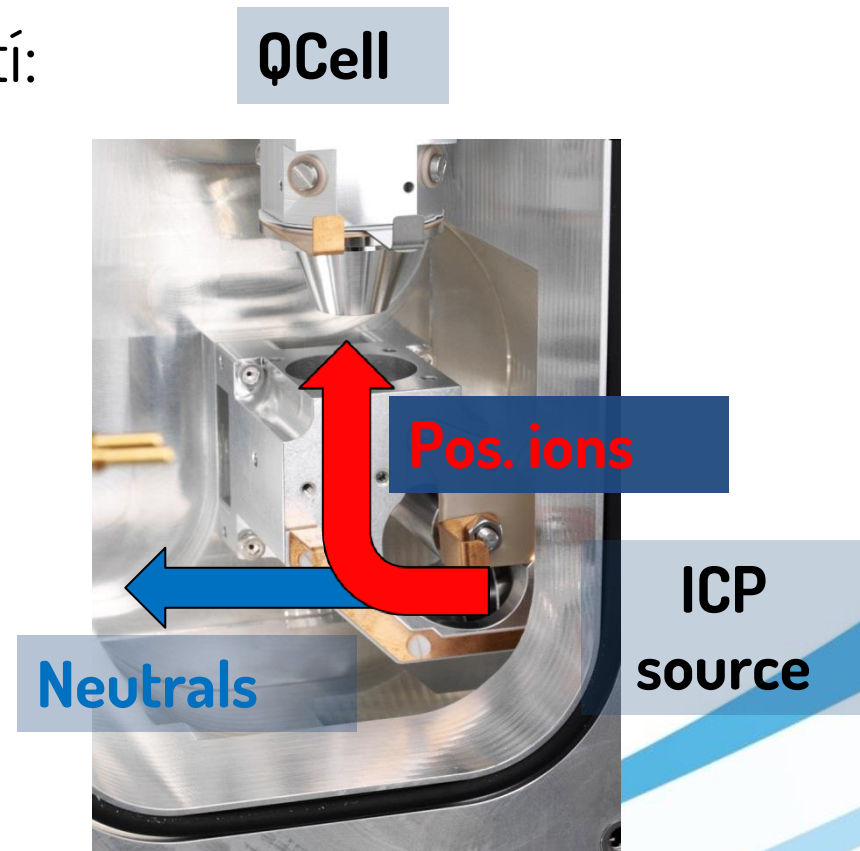

ICP-Q-MS

- Kvadrupólová separace iontů ($m/z=4-290$ amu)
- Eliminace interferencí pomocí kolizní/reakční cely (CRC)
- Rozsah linearity více než 9 řádů
- Background < 1 (0.5 cps)
- Vysoký poměr Signál/Šum (S/N)
- Nejrychlejší skenování hm. škály (90 000 amu/s)
- Minimální údržba

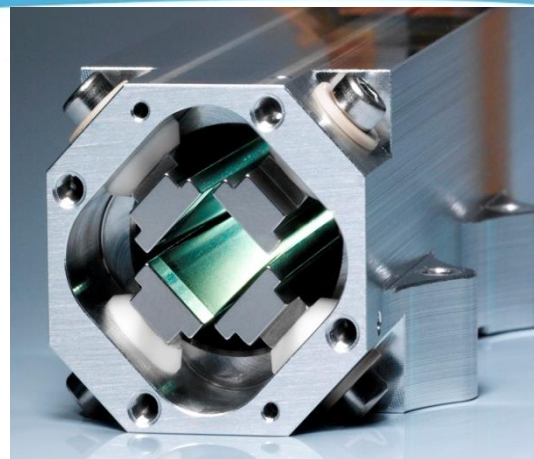

„FLATAPÓL“

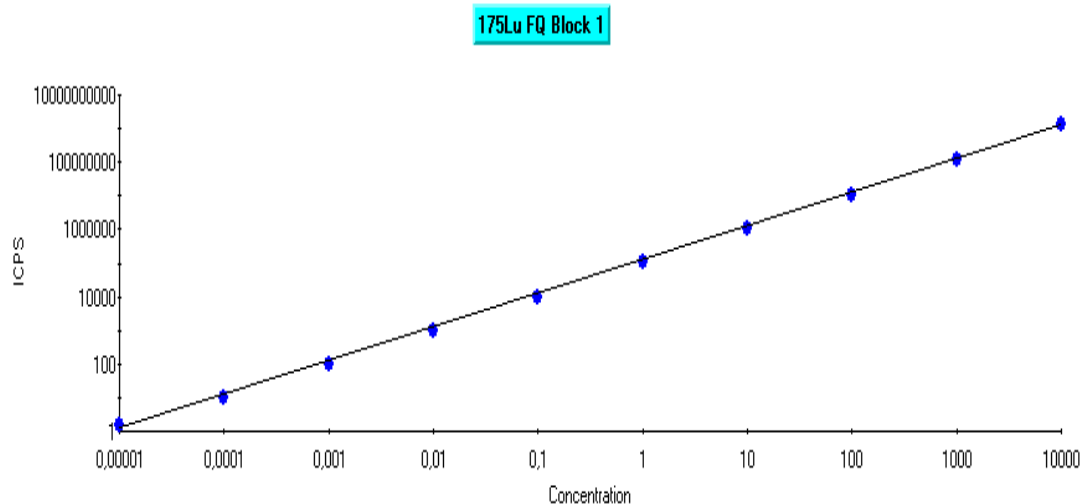

Intercept CPS=0,000000 Intercept Conc=0,000000
Sensitivity=125159,462357 Correlation Coeff=0,999956



Flatapól = přibližně kvadrupól

- Pole Flatapólu je přibližně ekvivalentní poli kvadrupólu s prvky vyšších multipólů.
 - **Vysoká transmise**
 - **Potlačení (Cut-off) nízkých hmot**

Flatapole

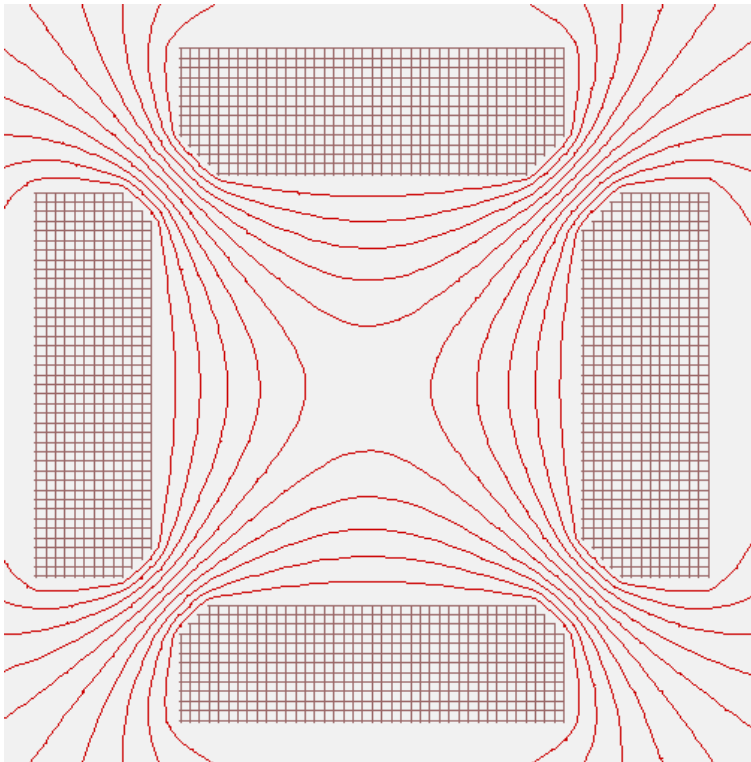

Quadrupole

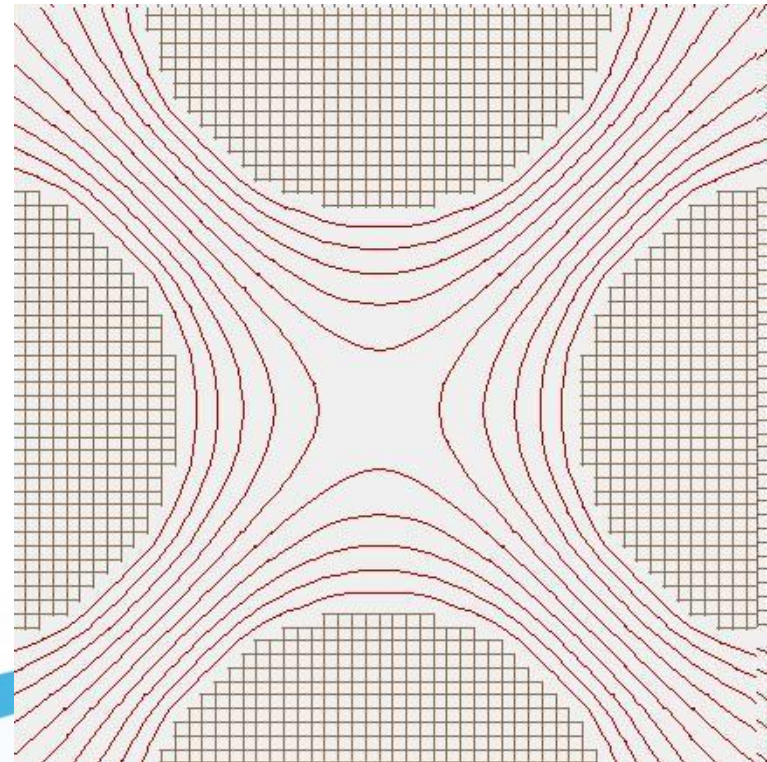

Funkce potlačení nízkých hmot

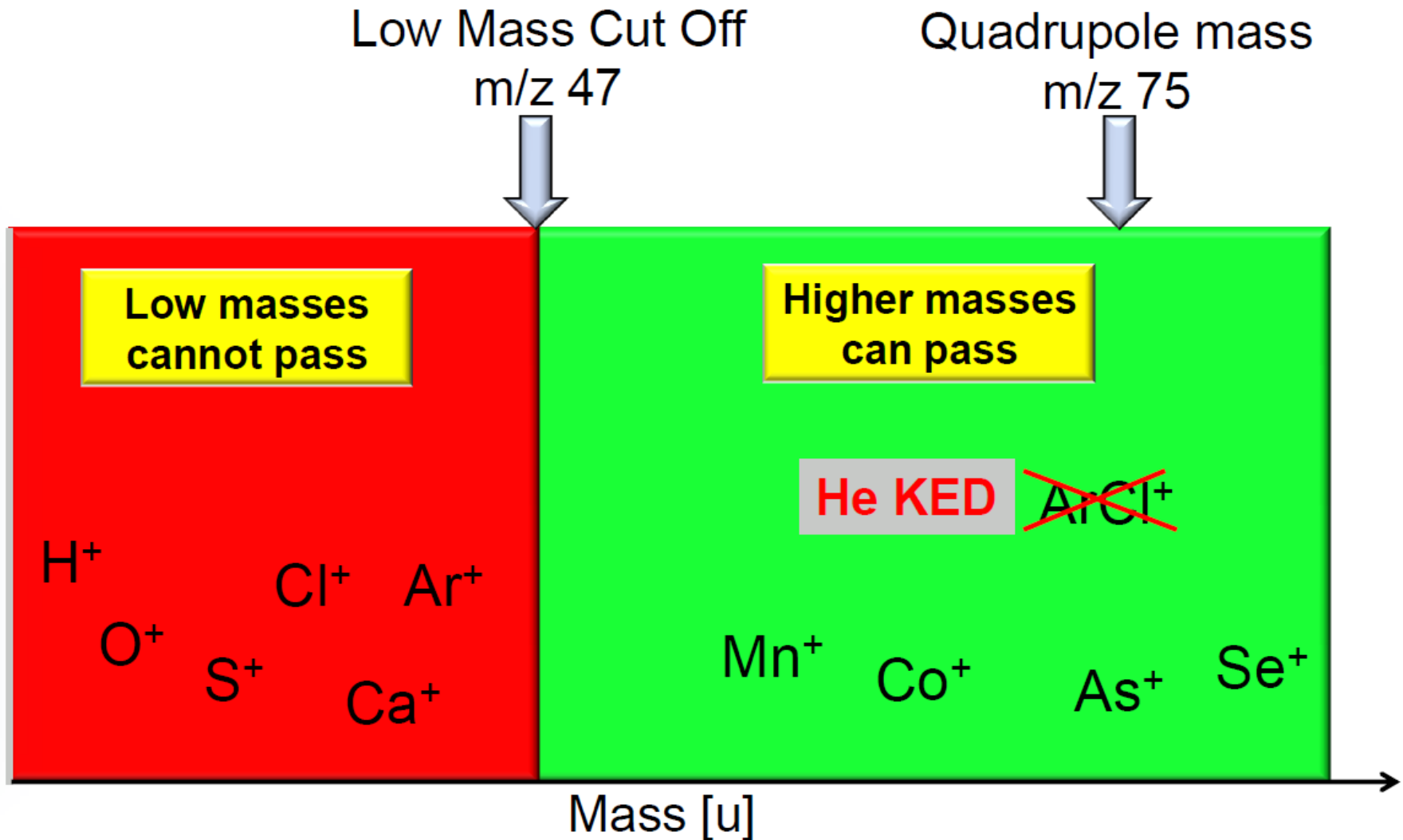

Effect of Low Mass Cut-Off on in-cell Interference

ANALYTE	CUT-OFF MASS	POTENTIAL INTERFERENT	PRECURSORS
⁴⁵ Sc	29	¹³ C ¹⁶ O ₂ , ¹² C ¹⁶ O ₂ H, ⁴⁴ CaH, ³² S ¹² CH, ³² S ¹³ C, ³³ S ¹² C	H, C, O, S, Ca
⁴⁷ Ti	32	³¹ P ¹⁶ O, ⁴⁶ CaH, ³⁵ Cl ¹² C, ³² S ¹⁴ NH, ³³ S ¹⁴ N	H, C, N, O, P, S, Cl, Ca
⁴⁹ Ti	33	³¹ P ¹⁸ O, ⁴⁸ CaH, ³⁵ Cl ¹⁴ N, ³⁷ Cl ¹² C, ³² S ¹⁶ OH, ³³ S ¹⁶ O	H, C, N, O, P, S, Cl, Ca
⁵⁰ Ti	34	³⁴ S ¹⁶ O, ³² S ¹⁸ O, ³⁵ Cl ¹⁴ NH, ³⁷ Cl ¹² CH	H, C, N, O, S, Cl
⁵¹ V	35	³⁵ Cl ¹⁶ O, ³⁷ Cl ¹⁴ N, ³⁴ S ¹⁶ OH	H, O, N, S, Cl
⁵² Cr	36	³⁶ Ar ¹⁶ O, ⁴⁰ Ar ¹² C, ³⁵ Cl ¹⁶ OH, ³⁷ Cl ¹⁴ NH, ³⁴ S ¹⁸ O	H, C, O, N, S, Cl, Ar
⁵⁵ Mn	39	³⁷ Cl ¹⁸ O, ²³ Na ³² S, ²³ Na ³¹ PH	H, O, Na, P, S, Cl, Ar
⁵⁶ Fe	39	⁴⁰ Ar ¹⁶ O, ⁴⁰ Ca ¹⁶ O	O, Ar, Ca
⁵⁷ Fe	40	⁴⁰ Ar ¹⁶ OH, ⁴⁰ Ca ¹⁶ OH	H, O, Ar, Ca
⁵⁸ Ni	41	⁴⁰ Ar ¹⁸ O, ⁴⁰ Ca ¹⁸ O, ²³ Na ³⁵ Cl	O, Na, Cl, Ar, Ca
⁵⁹ Co	42	⁴⁰ Ar ¹⁸ OH, ⁴³ Ca ¹⁶ O, ²³ Na ³⁵ ClH	H, O, Na, Cl, Ar, Ca
⁶⁰ Ni	43	⁴⁴ Ca ¹⁶ O, ²³ Na ³⁷ Cl	O, Na, Cl, Ca
⁶¹ Ni	44	⁴⁴ Ca ¹⁶ OH, ³⁸ Ar ²³ Na, ²³ Na ³⁷ ClH	H, O, Na, Cl, Ca
⁶³ Cu	45	⁴⁰ Ar ²³ Na, ¹² C ¹⁶ O ³⁵ Cl, ¹² C ¹⁴ N ³⁷ Cl, ³¹ P ³² S, ³¹ P ¹⁶ O ₂	C, N, O, Na, P, S, Cl
⁶⁴ Zn	46	³² S ¹⁶ O ₂ , ³² S ₂ , ³⁶ Ar ¹² C ¹⁶ O, ³⁸ Ar ¹² C ¹⁴ N, ⁴⁸ Ca ¹⁶ O	C, N, O, S, Ar, Ca
⁶⁵ Cu	47	³² S ¹⁶ O ₂ H, ³² S ₂ H, ¹⁴ N ¹⁶ O ³⁵ Cl, ⁴⁸ Ca ¹⁶ OH	H, N, O, S, Cl, Ca
⁶⁶ Zn	47	³⁴ S ¹⁶ O, ³² S ³⁴ S, ³³ S, ⁴⁸ C, ¹⁸ O	O, C, S
⁶⁹ Ga	47	³² S ¹⁸ O ₂ H, ³⁴ S ₂ H, ³⁷ Cl ¹⁶ O ₂	H, O, S, Cl
⁷⁰ Zn	47	³⁴ S ¹⁸ O ₂ , ³⁵ Cl ₂	O, S, Cl
⁷⁵ As	47	⁴⁰ Ar ³⁴ SH, ⁴⁰ Ar ³⁵ Cl, ⁴⁰ Ca ³⁵ Cl, ³⁷ Cl ₂ H	H, S, Cl, Ca, Ar
⁷⁷ Se	47	⁴⁰ Ar ³⁷ Cl, ⁴⁰ Ca ³⁷ Cl	Cl, Ca, Ar
⁷⁸ Se	47	⁴⁰ Ar ³⁸ Ar	Ar
⁸⁰ Se	47	⁴⁰ Ar ₂ , ⁴⁰ Ca ₂ , ⁴⁰ Ar ⁴⁰ Ca, ³² S ₂ ¹⁶ O, ³² S ¹⁶ O ₃	O, S, Ar, Ca

Effect of Low Mass Cut-Off on in-cell Interference Formation

ANALYTE	CUT-OFF-MASS	POTENTIAL INTERFERENT	PRECURSORS
⁴⁵ Sc	29	¹³ C ¹⁶ O ₂ , ¹² C ¹⁶ O ₂ H, ⁴⁴ CaH, ³² S ¹² CH, ³² S ¹³ C, ³³ S ¹² C	H, C, O, S, Ca
⁴⁷ Ti	32	³¹ P ¹⁶ O, ⁴⁶ CaH, ³⁵ Cl ¹² C, ³² S ¹⁴ NH, ³³ S ¹⁴ N	H, C, N, O, P, S, Cl, Ca
⁴⁹ Ti	33	³¹ P ¹⁸ O, ⁴⁸ CaH, ³⁵ Cl ¹⁴ N, ³⁷ Cl ¹² C, ³² S ¹⁶ OH, ³³ S ¹⁶ O	H, C, N, O, P, S, Cl, Ca
⁵⁰ Ti	34	³⁴ S ¹⁶ O, ³² S ¹⁸ O, ³⁵ Cl ¹⁴ NH, ³⁷ Cl ¹² CH	H, C, N, O, S, Cl
⁵¹ V	35	³⁵ Cl ¹⁶ O, ³⁷ Cl ¹⁴ N, ³⁴ S ¹⁶ OH	H, O, N, S, Cl
⁵² Cr	36	³⁶ Ar ¹⁶ O, ⁴⁰ Ar ¹² C, ³⁵ Cl ¹⁶ OH, ³⁷ Cl ¹⁴ NH, ³⁴ S ¹⁸ O	H, C, O, N, S, Cl, Ar
⁵⁵ Mn	39	³⁷ Cl ¹⁸ O, ²³ Na ³² S, ²³ Na ³¹ PH	H, O, Na, P, S, Cl, Ar
⁵⁶ Fe	39	⁴⁰ Ar ¹⁶ O, ⁴⁰ Ca ¹⁶ O	O, Ar, Ca
⁵⁷ Fe	40	⁴⁰ Ar ¹⁶ OH, ⁴⁰ Ca ¹⁶ OH	H, O, Ar, Ca
⁵⁸ Ni	41	⁴⁰ Ar ¹⁸ O, ⁴⁰ Ca ¹⁸ O, ²³ Na ³⁵ Cl	O, Na, Cl, Ar, Ca
⁵⁹ Co	42	⁴⁰ Ar ¹⁸ OH, ⁴³ Ca ¹⁶ O, ²³ Na ³⁵ ClH	H, O, Na, Cl, Ar, Ca
⁶⁰ Ni	43	⁴⁴ Ca ¹⁶ O, ²³ Na ³⁷ Cl	O, Na, Cl, Ca
⁶¹ Ni	44	⁴⁴ Ca ¹⁶ OH, ³⁸ Ar ²³ Na, ²³ Na ³⁷ ClH	H, O, Na, Cl, Ca
⁶³ Cu	45	⁴⁰ Ar ²³ Na, ¹² C ¹⁶ O ³⁵ Cl, ¹² C ¹⁴ N ³⁷ Cl, ³¹ P ³² S, ³¹ P ¹⁶ O ₂	C, N, O, Na, P, S, Cl
⁶⁴ Zn	46	³² S ¹⁶ O ₂ , ³² S ₂ , ³⁶ Ar ¹² C ¹⁶ O, ³⁸ Ar ¹² C ¹⁴ N, ⁴⁸ Ca ¹⁶ O	C, N, O, S, Ar, Ca
⁶⁵ Cu	47	³² S ¹⁶ O ₂ H, ³² S ₂ H, ¹⁴ N ¹⁶ O ³⁵ Cl, ⁴⁸ Ca ¹⁶ OH	H, N, O, S, Cl, Ca
⁶⁶ Zn	47	³⁴ S ¹⁶ O, ³² S ³⁴ S, ³³ S, ⁴⁸ C, ¹⁸ O	O, C, S
⁶⁷ Zn	47	³² S ³⁴ SH, ³³ S ₂ H, ⁴⁸ Ca ¹⁸ OH, ¹⁴ N ¹⁶ O ³⁷ Cl, ³⁵ Cl ¹⁶ O ₂	H, N, O, S, Cl, Ca
⁶⁸ Zn	47	³² S ¹⁸ O ₂ , ³⁴ S ₂	O, S
⁶⁹ Ga	47	³² S ¹⁸ O ₂ H, ³⁴ S ₂ H, ³⁷ Cl ¹⁶ O ₂	H, O, S, Cl
⁷⁰ Zn	47	³⁴ S ¹⁸ O ₂ , ³⁵ Cl ₂	O, S, Cl
⁷⁵ As	47	⁴⁰ Ar ³⁴ SH, ⁴⁰ Ar ³⁵ Cl, ⁴⁰ Ca ³⁵ Cl, ³⁷ Cl ₂ H	H, S, Cl, Ca, Ar
⁷⁷ Se	47	⁴⁰ Ar ³⁷ Cl, ⁴⁰ Ca ³⁷ Cl	Cl, Ca, Ar
⁷⁸ Se	47	⁴⁰ Ar ³⁸ Ar	Ar
⁸⁰ Se	47	⁴⁰ Ar ₂ , ⁴⁰ Ca ₂ , ⁴⁰ Ar ⁴⁰ Ca, ³² S ₂ ¹⁶ O, ³² S ¹⁶ O ₃	O, S, Ar, Ca

Praktické výhody potlačení nízkých m/z s QCell

- Potlačení nízkých hmot eliminuje potenciální interference species vstupujících do kolizní cely.
- Tím je významně redukován vliv možných interferencí vlivem tvorby nových interferentů.
- Diskriminace kinetickou energií je tak mnohem efektivnější.
- Reaktivní „chemie“ fungují rovněž mnohem efektivněji.

QCell „Výkon“ – „Interference-free“ analýza P, Si, S

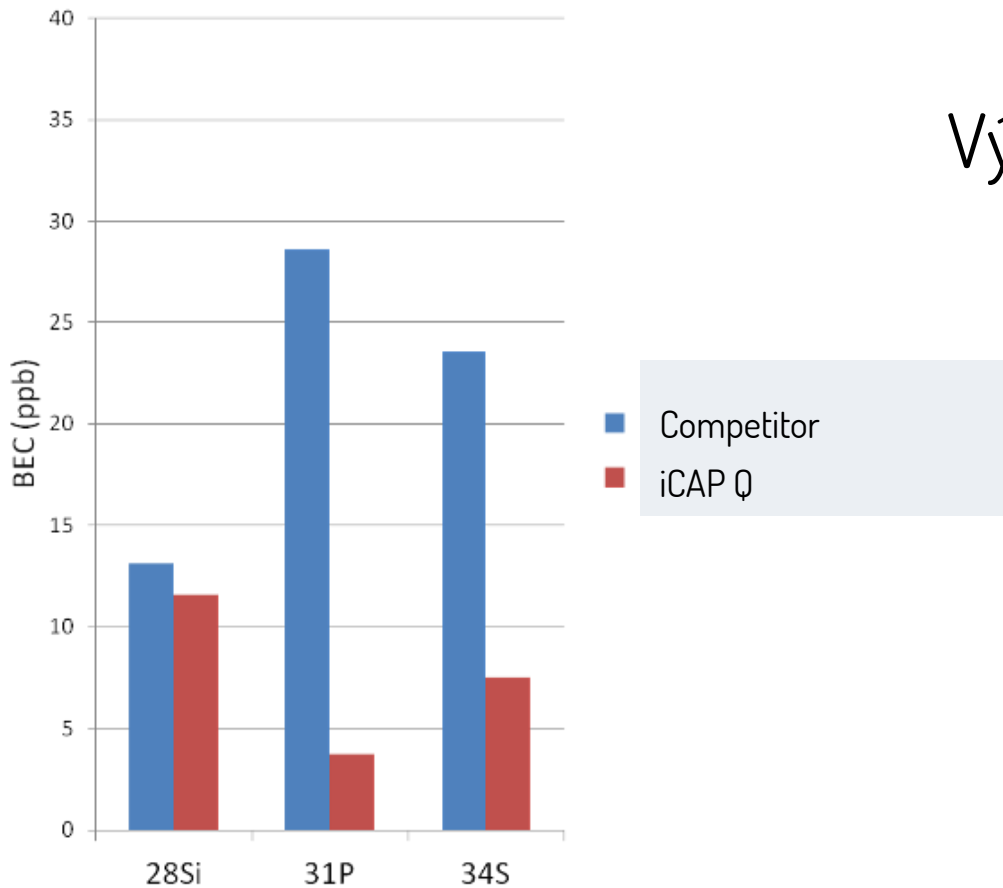

Výsledky:

- Si: He KED
- P: He KED
- S: $^{32}\text{S}^{16}\text{O}$ at m/z 48
- BEC nižší než konkurence

BEC = Background Equivalent Concentration

Výběr ICP-MS „dle parametrů“

Vysoká citlivost

Vysoká tolerance vůči matici

- UNIQUE Cone Inserts
 - Allows variation of central channel length
 - Interchangeable on iCAP Qc to vary instrument properties

Insert	Channel length	Properties
High Matrix	3.5 mm	High matrix tolerance
High Sensitivity	2.8 mm	High sensitivity



Porovnání produktových specifikací – technické parametry

Lets look at the sensitivity specification and mass response for the iCAP Qc with High Matrix insert:

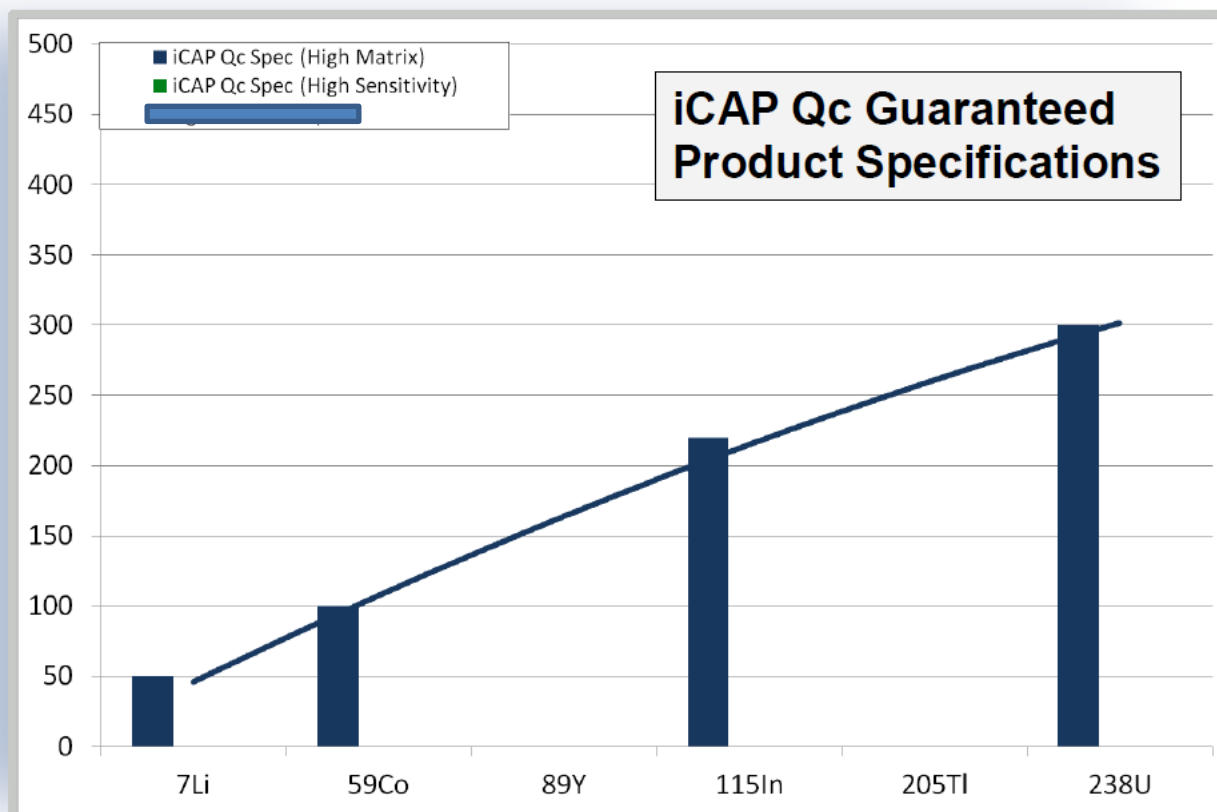

**Sensitivity
Performance
High Sensitivity**

$$= 1.5 \times$$

**Sensitivity
Performance
High Matrix**

- Now add the sensitivity performance and mass response for the iCAP Qc with High Sensitivity insert:

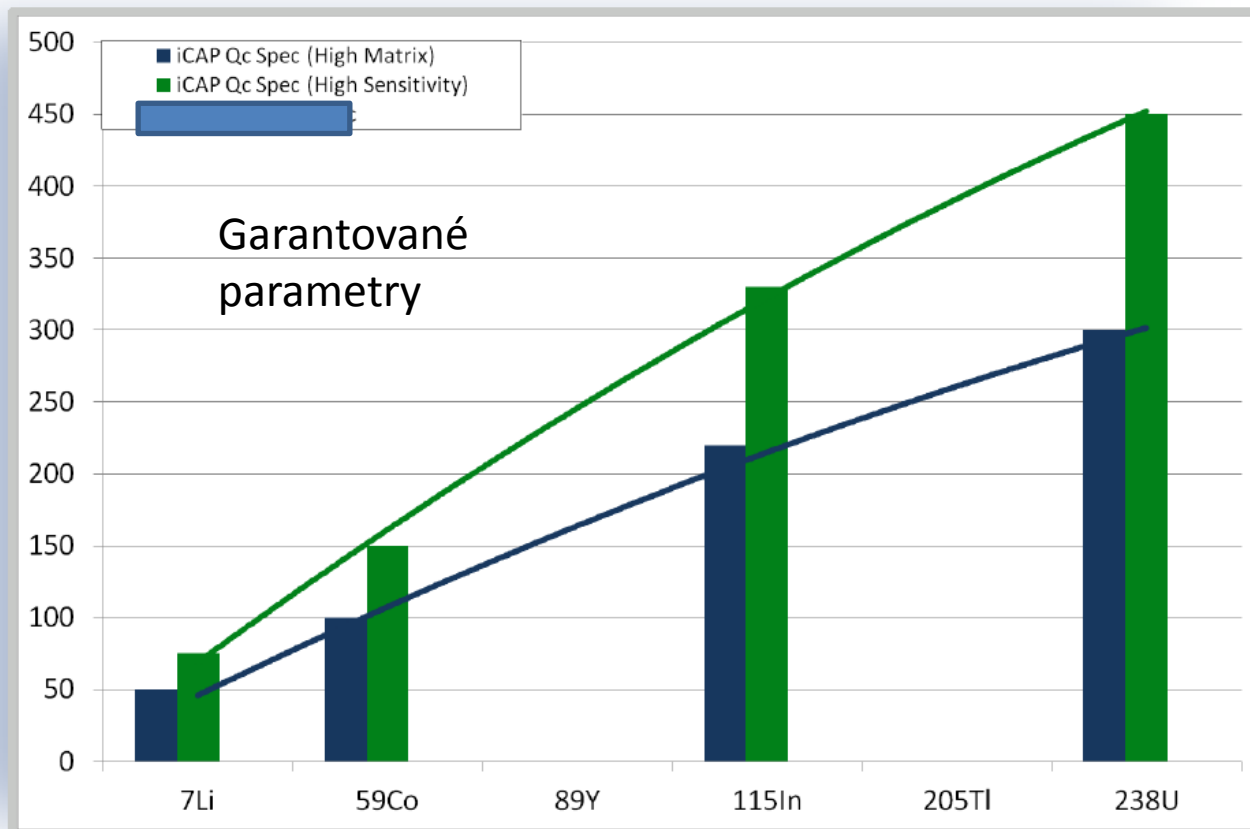

Porovnání Garantovaných parametrů

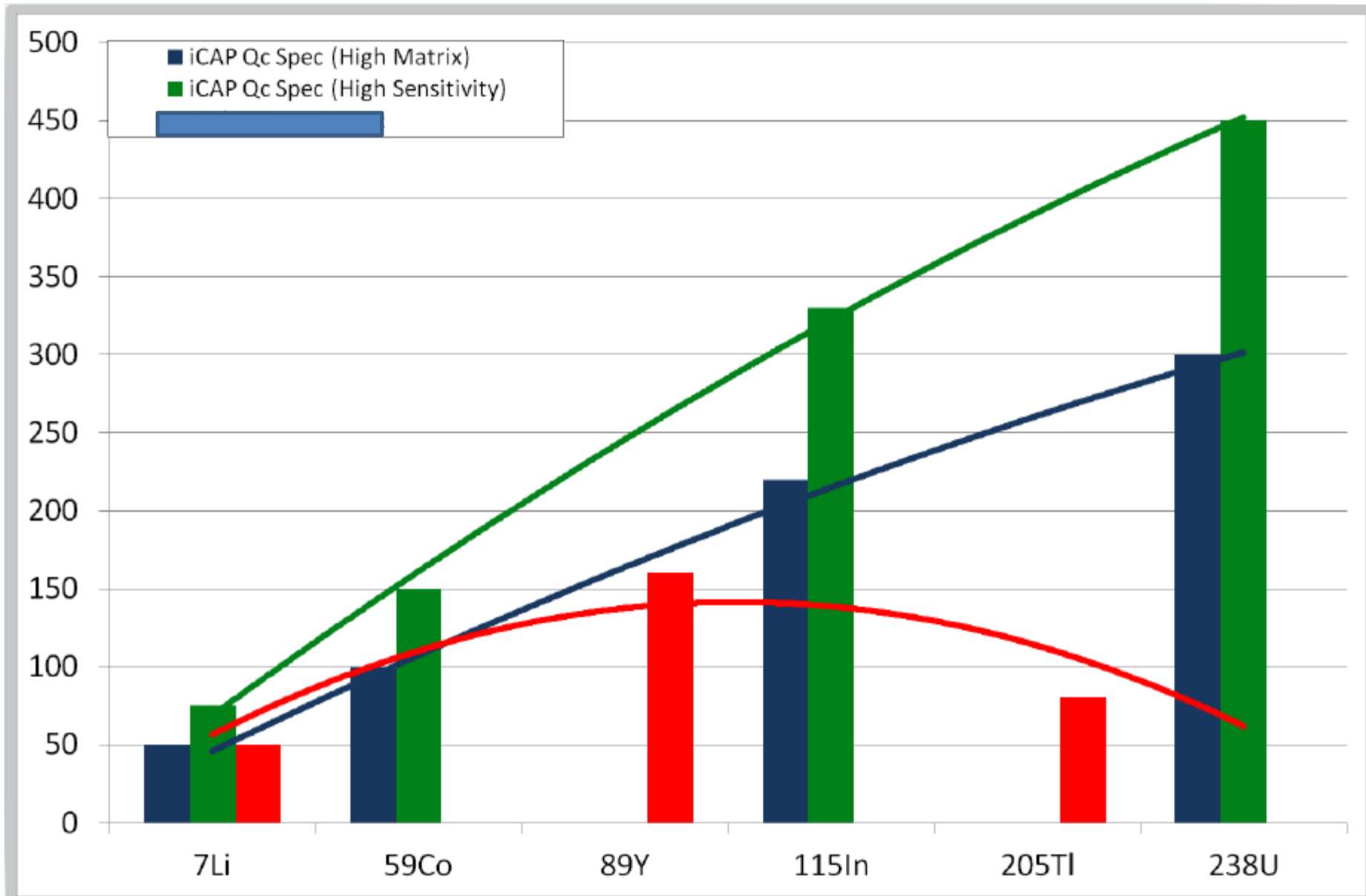

The iCAP Qc typical performance with the High Sensitivity interface

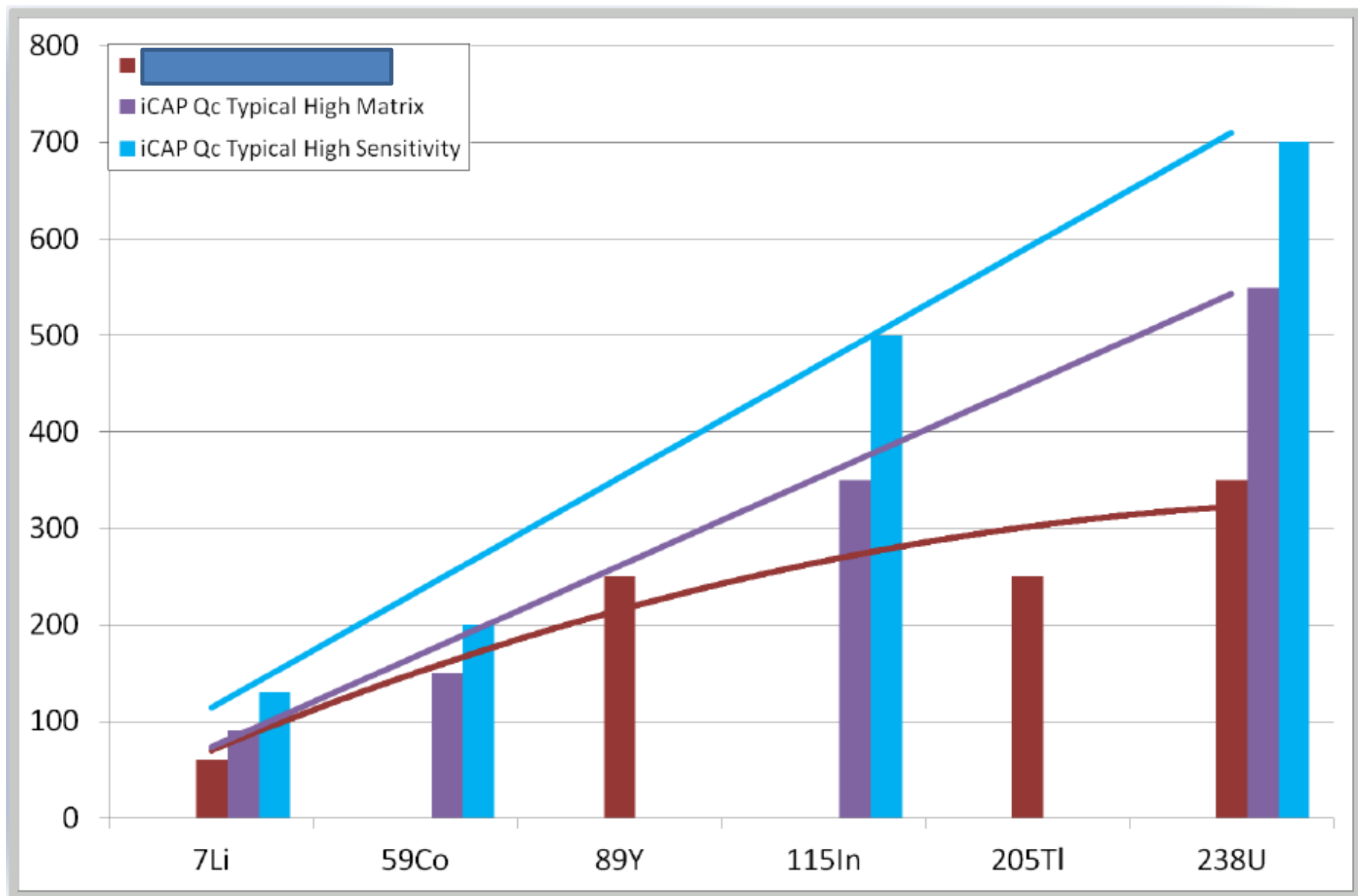

iCAP Q Interface Cone Access



Demonstrace odolnosti vůči vzorkové matici

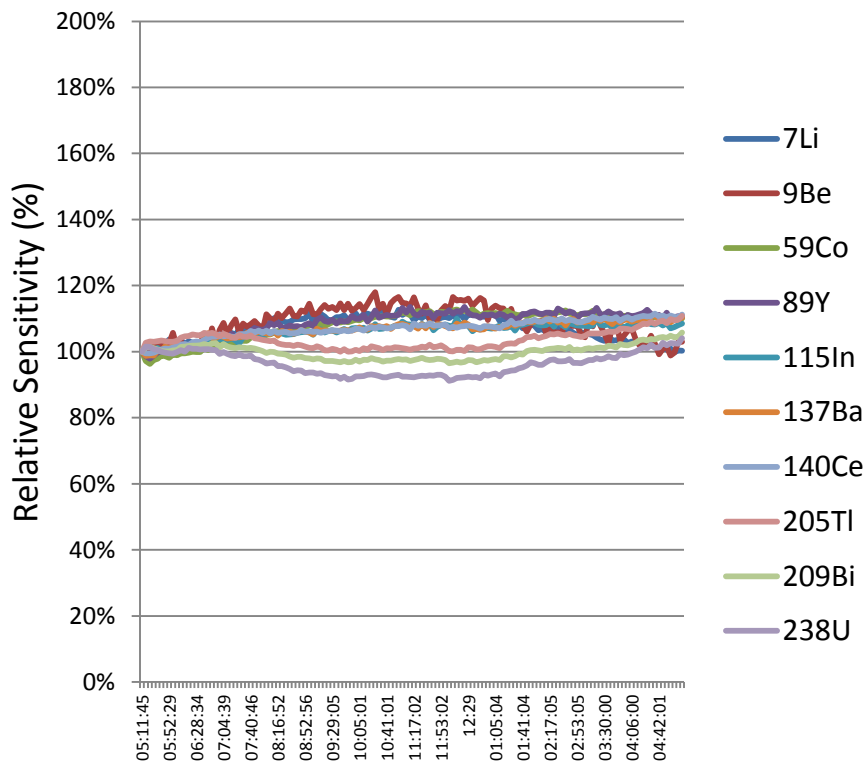

- Podmínky testu:
 - Kontinuální aspirace 10xřředěné „obohacené“ mořské vody (~0.35 % rozpuštěných pevných látek)
- Výsledky:
 - Přesahující obecné požadavky
 - Bez ztráty citlivosti
 - Celkový drift <10%
 - Vzorkové kóny zůstávají funkční a průchodné

Kvantifikace organického solventu: 100% ACN

Stabilita za 12 hodin
všechny elementy <5% RSD

„Spike Recovery“ (1ppb) v 100% ACN) 90-110%
získání

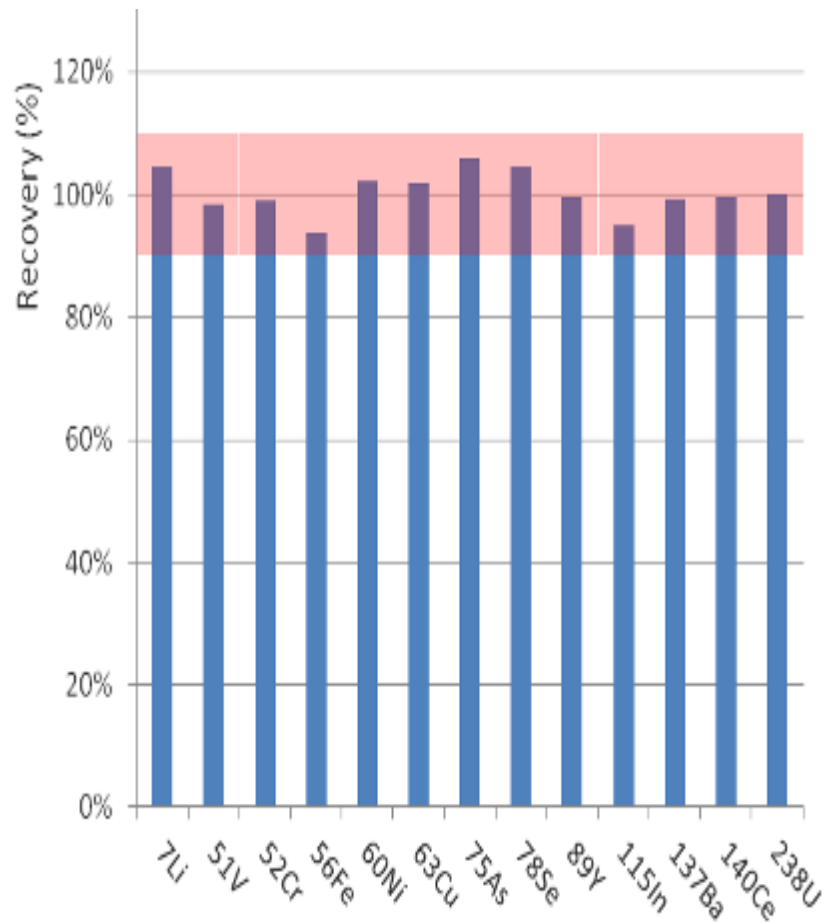
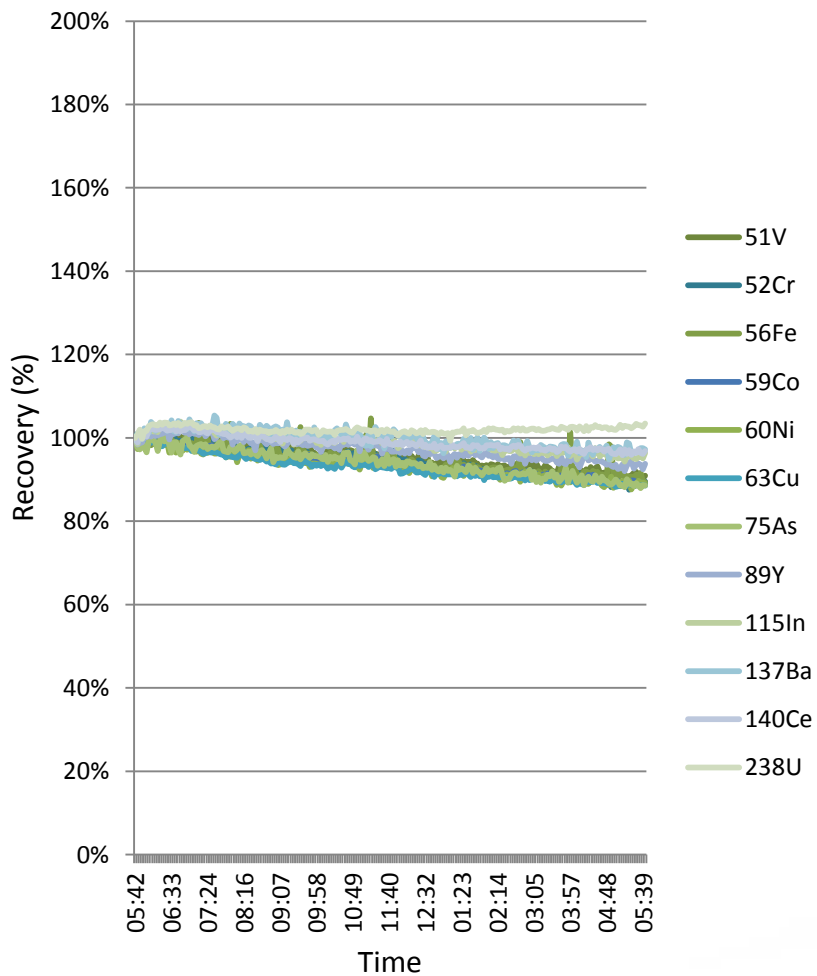

Děkují za pozornost

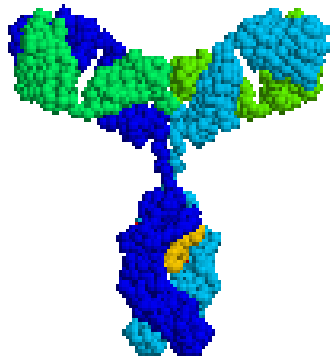

JANDERKA@PRAGOLAB.CZ

SW Qtegra: „Nová multi-instrumentální **platforma** uživatelského rozhraní“



Speciační analýza

- **Definice** – ‘Analytická aktivita směřující k identifikaci a kvantifikaci jedné nebo více individuálních chemických „species“ ve vzorku’ **IUPAC**
- **To znamená** – spíše než celkový obsah, je cílem snažení kvantifikace jednotlivých chemických forem
- **Příklad** – „formy-stavy“ sloučenin rtuti separované pomocí vysoceúčinné separační techniky a detekované pomocí ICP-MS

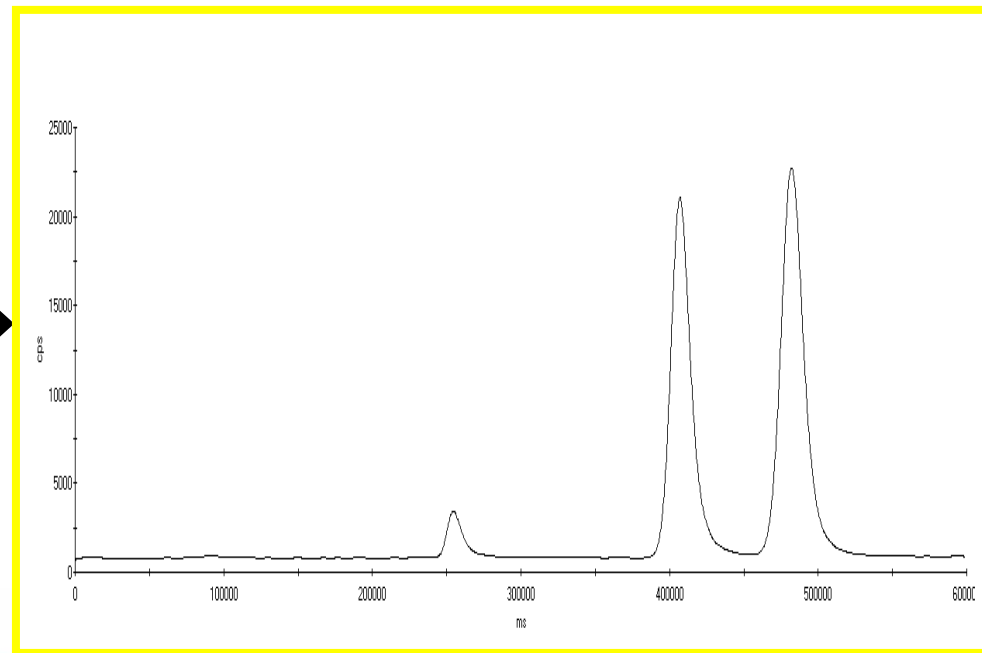
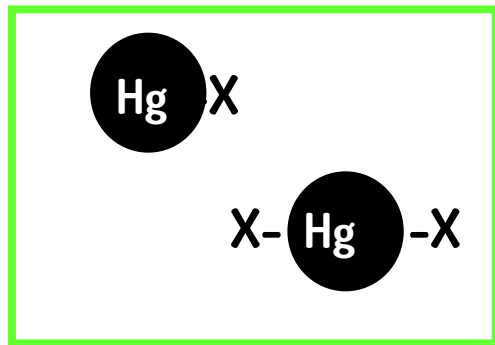

Proč potřebujeme speciaci...?

Biodostupnost

Vysoká citlivost

Environmentální osudy

Vysoká selektivita

Mobilita

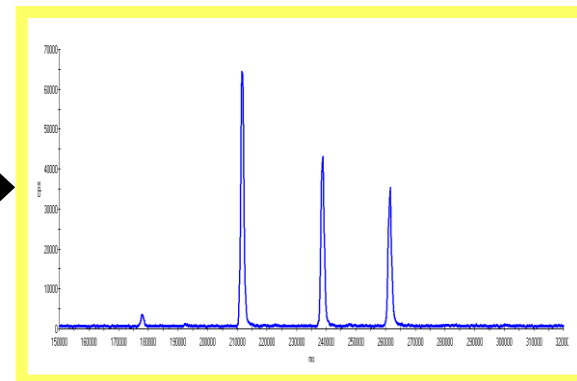
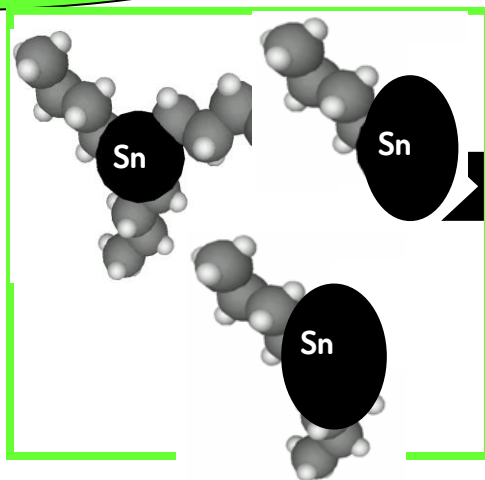

Toxicita

Multi-Element/Isotope

Kontrola procesů a výroby

Těkavé prvkové sloučeniny

TFS - Flexibilní speciální produktové balíky

- GC
- HPLC
- IC (Ion Chromatography)



Zcela inertní IC / LC navržené
na speciaci kovů

LC spojení (Accela)

Trace(s) of Analysis No 4 : "Level 4"

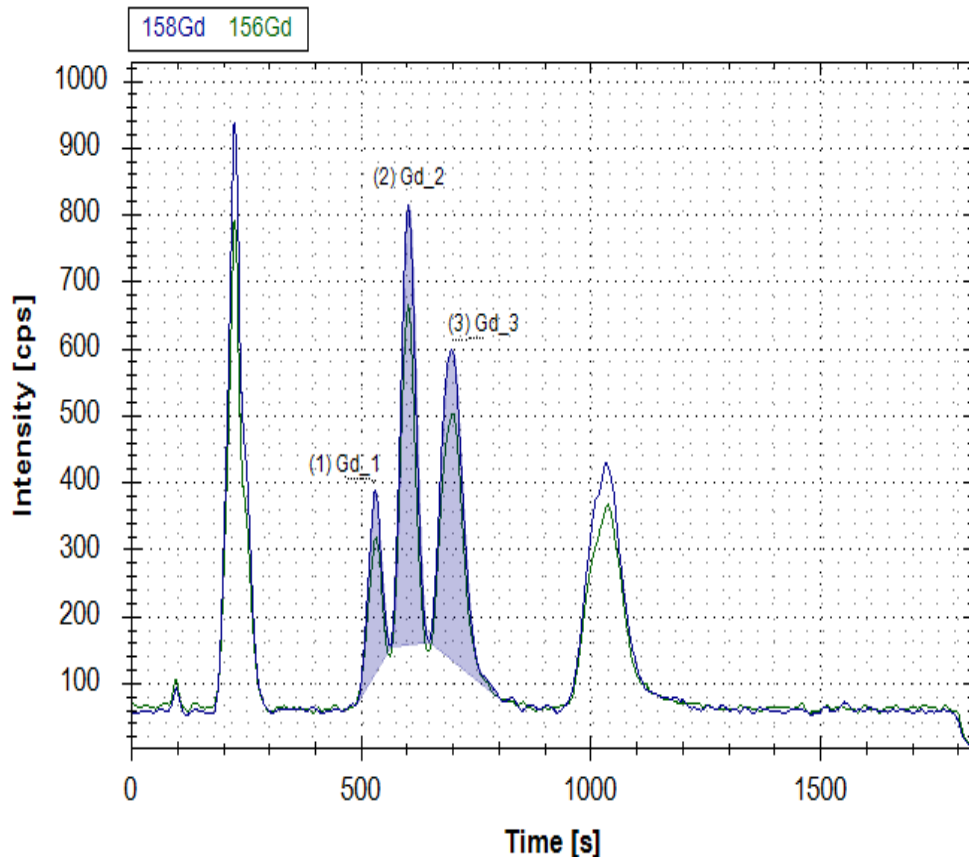

- Plasma stable in reverse – phase LC applications with ACN gradients as mobile phase with O₂ additional plasma gas
- Software:
 - Qtegra plug-in in place for LC control and triggering

LC spojení (Dionex)

Alkylcíny

Trace(s) of Analysis No 6 : "5 ppb"

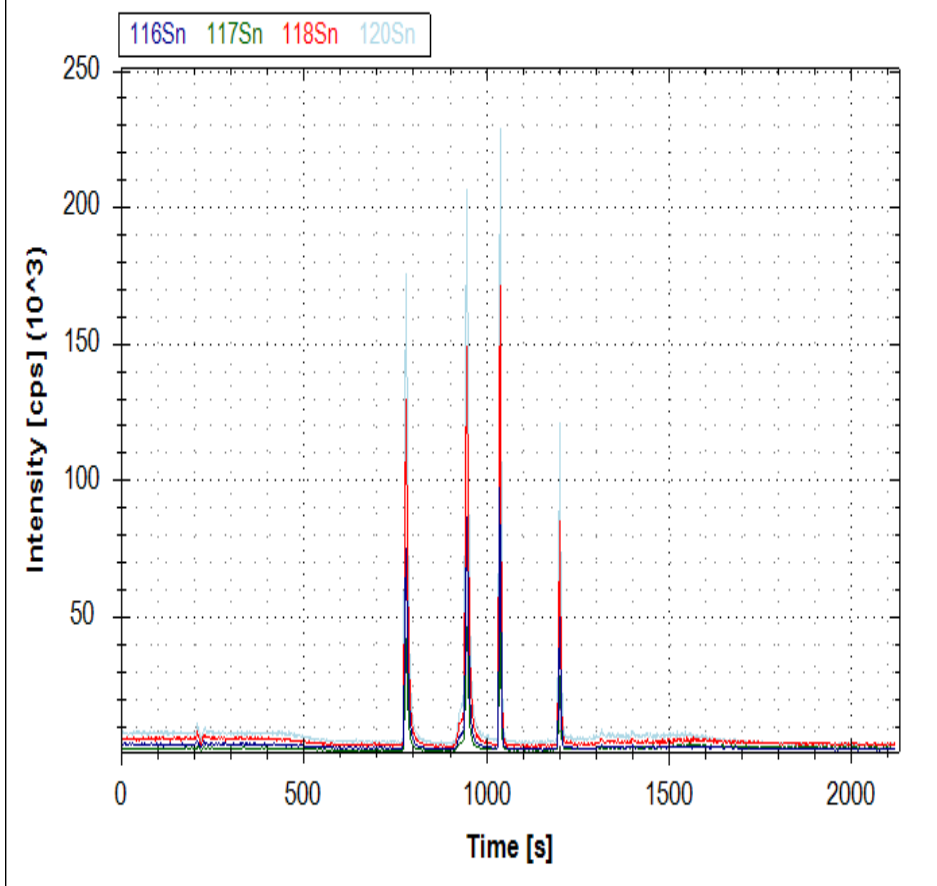

- Dionex ICS-5000+ analytical quaternary pump
 - Reverse phase LC: 10% acetic acid with 10-90% ACN gradient mobile phase @ 200 $\mu\text{l}\cdot\text{min}^{-1}$



Měřicí módy pro speciace

- **STD mód**

Pro nejvyšší citlivost neinterferujících analytů, např. Hg, Pb

- **KED mód**

Odstranění interferencí pomocí QCell s použitím He a Diskriminací kinetickou energií, analyty např. Cr, V, As

- **CCT mód**

QCell naplněná buď He nebo jiným plynem, např. směs He/H₂, O₂ atd.) v reakčním módu pro zvýšení citlivosti (Pb, Hg, Sn atd.) nebo pro odstranění interferencí v plynné fázi reakcemi – As, Se, S

Několik příkladů reálných speciálních analýz



Aplikační listy iCAP Q + IC Diorex

Total and speciation analysis of Mercury in contact lens solutions by ICP-MS

Daniel Kütcher, Julian Will, Lohrer Rottmann, Thermo Fisher Scientific, Germany

Key Words
ICAP Q, ICP-MS, ICS-5000, ion chromatography, Thimerosal, Hg, speciation

Goal
To develop a fully quantitative method for the determination of both total Hg and Hg species in contact lens solutions.

Introduction
While there is continual awareness regarding exposure to mercury (Hg) sources in general and MeHg in particular due to its presence in food samples such as fish, less interest is paid to the potential risk from ethylmercury (EtHg, or EtHgX). One of the main reasons for this is the faster degradation and consequently excretion of EtHg in the human body that results in considerably lower chronic toxicity. There remain however potential sources where acute intake of EtHg can occur, for example as a consequence of exposure to thimerosal. Thimerosal is used as a bactericide in multi-dose (typical concentration 0.001 to 0.01%) and in other health related products such as eye drops or contact lens solutions. The compound hydrolyses in aqueous solution to form EtHg and thioacetate which is an effective bactericide. Although no direct correlation between thimerosal usage and potential health risks has been established, the use of thimerosal has been reduced in both Germany and the USA. In use it is still permitted in multi dose vaccines and contact lens solutions at concentrations of up to 100 and 70 mg/kg respectively.

Sample and Calibration Solution Preparation
Three different commercially available contact lens solutions were prepared for total Hg and Hg speciation analysis. For total mercury analysis, the contact lens solutions were analyzed after a 2000-fold dilution in 2% HNO₃ / 0.5% HCl. However, as no detectable signal for mercury was found, a lower dilution factor (20-fold) was employed. For Hg speciation analysis, calibration standards were prepared in a matrix solution containing 0.5% NaCl and 0.01% EDTA to mimic the matrix of the contact lens solutions and to prevent the formation of the same mercury complexes as in the sample matrix (such as [HgCl₂]²⁺). The standards and the contact lens solutions were then diluted 2000-fold with ultra high purity water prior to injection.

For total Hg determination, gold was added to the samples and the rinse solution to minimize memory effects from the sample introduction system.

Thermo SCIENTIFIC

IC-ICP-MS speciation analysis of As in Organic Brown Rice Syrup (OBRS) using the Thermo Scientific iCAP Q ICP-MS

Daniel Kütcher, Julian Will and Lohrer Rottmann, Thermo Fisher Scientific, Germany and Defei Jansen, Thermo Fisher Scientific, Switzerland

Key Words
ICAP Q, ICP-MS, ICS-5000, ion chromatography, As, speciation, food

Goal
The analysis of organic brown rice samples (OBRS) for their total arsenic content by ICP-MS and their species concentrations by IC-ICP-MS.

Introduction
Media reports and scientific publications on the determination of arsenic (As) in foodstuffs have sparked renewed interest from consumer groups and politicians leading to responses from national regulatory bodies. Following the publication of a report on high As levels in organic brown rice syrup (OBRS, an ingredient in a variety of organic foods) the United States Food and Drug Administration (FDA) stated that it was carrying out a study on As in rice and rice products that is due to report later in 2012.

Based on previous work¹, OBRS samples were analyzed for their total arsenic content by ICP-MS and then subsequently by IC-ICP-MS to determine the concentration of six arsenic species: the two toxic inorganic species (As(III) and As(V)), and four organic species that are considered to be harmless.

Instrument configuration
All measurements – both total As and As speciation – were carried out using the Thermo Scientific iCAP Q ICP-MS. As an analyser were performed in He-KED (Kinetic Energy Discrimination) mode, efficiently reduce polyatomic interferences of (monoisotopic) arsenic at m/z 77. Separations were carried out on Dionex ICS-5000 ion chromatography with the iCAP Q sensitive.



Sample Preparation
Three different OBRS samples were sourced and analyzed. For the total As analysis, the dried wheat digestion method described by Jackson et al. was used. Preparation of the OBRS samples for As speciation was achieved by taking 1.5 g of OBRS, ml of 0.28 M HNO₃, and refluxing for 90 min.

Total Arsenic Results
A calibration curve for the He-KED analysis of shown in Figure 1.



IC-ICP-MS speciation analysis of As in apple juice using the Thermo Scientific iCAP Q ICP-MS

Daniel Kütcher, Shona McSherry, Julian Will, Thermo Fisher Scientific, Germany, Defei Jansen, Thermo Fisher Scientific, Switzerland

Key Words
ICAP Q, Apple Juice, As, speciation, ion chromatography, ICS-5000

Goal
Apple juice samples are analyzed by IC-ICP-MS to determine the concentration of six arsenic species: two inorganic and toxic species (As(III) and As(V)) and four organic species (arsenobetaine (AsB), arsenocholine (AsC), monomethylarsinic acid (MMA) and dimethylarsinic acid (DMA)).

Introduction
Interest in the determination of arsenic (As) species in fruit juices has been triggered by media reports in the US claiming that some apple juices may contain high amounts of arsenic¹. Since fruit juices are frequently consumed, especially by young children, the reported values led to serious concerns about the safety of such products. However, in the experiments conducted, only the total arsenic concentration was assessed, but no detailed investigation of the chemical form of the element was carried out. This is an important distinction since the inorganic forms of arsenic (As(III) and As(V)) are highly toxic, while the organic forms (e.g. arsenobetaine) are not considered to be toxic. Typical levels of total arsenic found in apple juice are lower than the US EPA drinking maximum contaminant level (MCL) of 10 µg/L so apple juice is generally considered safe and is currently not regulated. However, as a consequence, the FDA is currently reviewing data, and may eventually tighten its current guidelines.

Instrument configuration
Chromatography Thermo Scientific system. Due to its proprietary 90° provides both high backgrounds with use of a He press (Discrimination) interferences in a KED mode also lower background at L analysis of (non possibility to use therefore the flux reduction Qc will minimize polyat would otherwise

General analyt
The iCAP Q ICP-MS is a sensitive and accurate elemental analyser. It is equipped with a high resolution interface (HRI) for the detection of low abundance species. The iCAP Q ICP-MS is equipped with a high resolution interface (HRI) for the detection of low abundance species. The iCAP Q ICP-MS is equipped with a high resolution interface (HRI) for the detection of low abundance species.

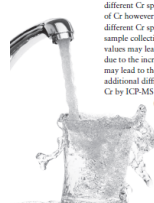

Speciation analysis of Cr(III) and Cr(VI) in drinking waters using anion exchange chromatography coupled to the Thermo Scientific iCAP Q ICP-MS

Daniel Kütcher, Shona McSherry, Julian Will, Thermo Fisher Scientific, Germany, Defei Jansen, Thermo Fisher Scientific, Switzerland

Key Words
ICAP Q, Cr speciation, ion chromatography, Drinking water, ICS-5000

Goal
To develop a sensitive, robust and high throughput method for the trace level analysis of Cr(III) and Cr(VI) species in natural waters using IC-ICP-MS.

Introduction
Due to its widespread use in industrial applications such as chromium plating, dye manufacturing and preservation of wood and leather materials, chromium concentrations in environmental samples are monitored on a routine basis. Both the United States EPA and the European Union have specified maximum admissible chromium concentrations in their respective drinking water directives. As with many other trace elements, chromium (Cr) is typically found in more than one chemical form, each of which with different chemical properties and behavior such as bioavailability and toxicity. For chromium, Cr(III) is essential to human beings and involved in different processes in the body while Cr(VI) is highly toxic. Total Cr content therefore is, for example, a drinking water sample does not provide sufficient information to evaluate potential hazards to populations exposed to it. In order to provide this critical information a supporting speciation analysis is required to determine the amounts of the different Cr species in the sample. The speciation analysis of Cr however is a challenging task, since the stability of different Cr species is easily affected by conditions during sample collection and treatment¹. For example, low pH values may lead to the degradation of Cr(VI) to Cr(III) due to the increased redox potential, while high pH values may lead to the precipitation of Cr(III) as Cr(OH)₃. An additional difficulty in the accurate speciation analysis of Cr by ICP-MS are the numerous spectral interferences (e.g. ²³⁵UO²⁺ or ²³⁸UO²⁺) on the most abundant chromium isotopes, ⁵²Cr.



Thermo SCIENTIFIC

Thermo SCIENTIFIC

Application Note

TESTING INSTRUMENT

TESTING INSTRUMENT

IC-ICP-MS for the Speciation of Cr (III) and Cr (VI)

Column	Dionex AG-7 (2x50mm)
---------------	-----------------------------

Mobile Phase	0.35 mol L ⁻¹ HNO ₃
--------------	---

Flow rate	0.4 mL min ⁻¹
-----------	--------------------------

Injection volume	20 μL
------------------	-------

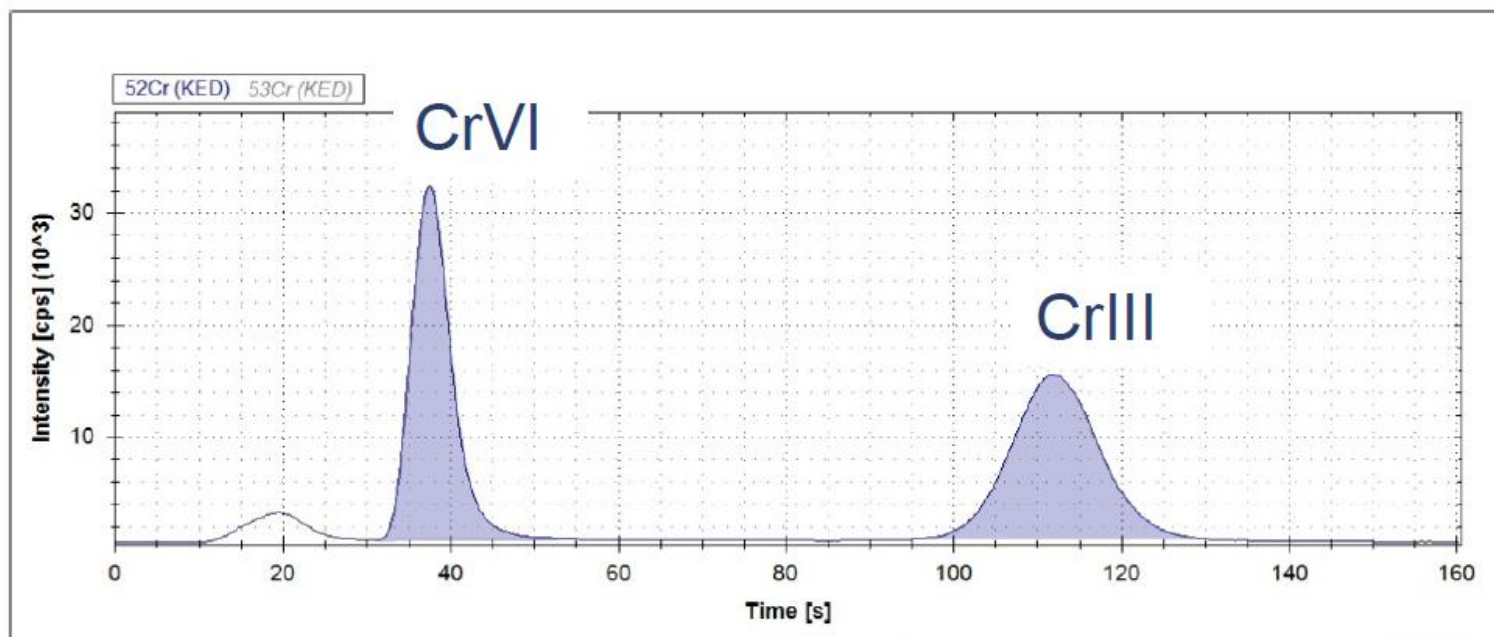

IC-ICP-MS for the Speciation of Cr (III) and Cr (VI)

- Both chromium isotopes, $^{52}, ^{53}\text{Cr}$, can be monitored
- Cr(III) and Cr(VI) are completely baseline separated
- Limits of detection:
 - **0.20 ng L⁻¹ [Cr (VI)]**
 - **0.38 ng L⁻¹ [Cr (III)]**
- Isocratic chromatography performed in less than 3 minutes

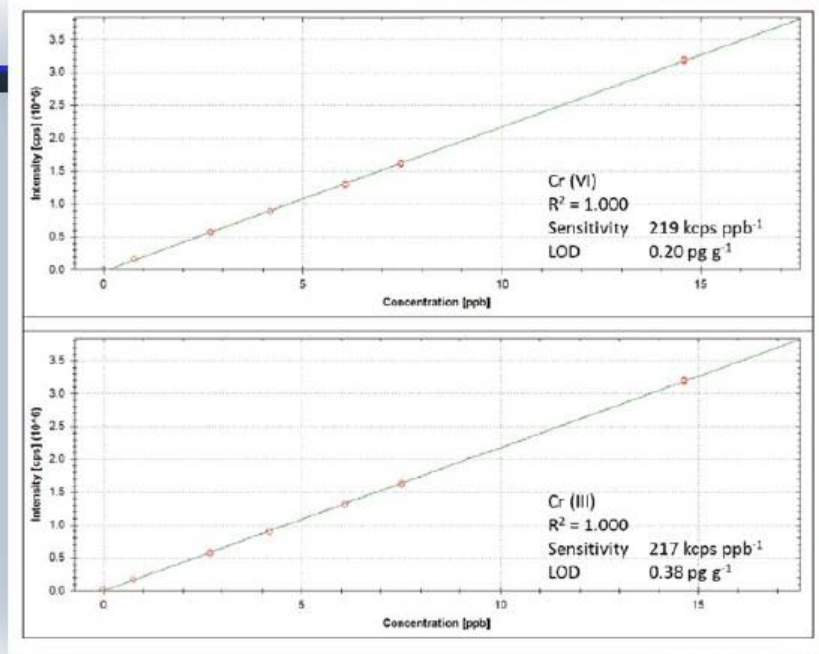

Speciation of Cr in Drinking Water

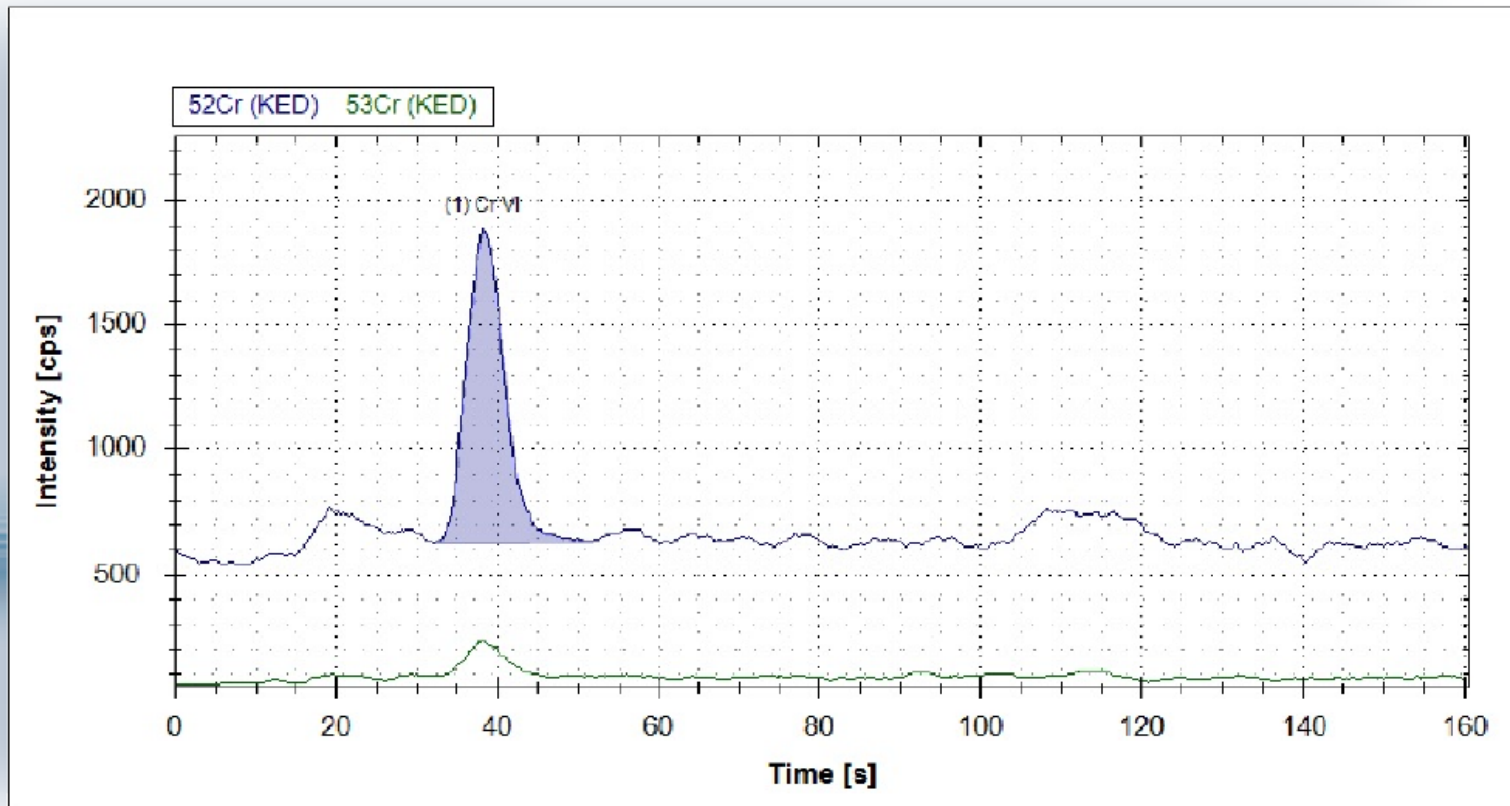

***Analysis of locally sourced tap water (Bremen):
Only Cr (VI) was detected, Concentration 42.5 ng L⁻¹
Injection without further sample treatment***

Chromium Speciation Analysis of Drinking Water

- A sensitive and fast method based on ion chromatography for the speciation of Cr has been developed
 - No need for the addition of EDTA or other charge pairing agents necessary, no additional sample preparation, no additional spectral interferences in the mass spectra
 - The IC eluent, dilute HNO_3 , is relatively cheap, easily sourced and allows detection of Cr species in the single digit ppt range
 - Reduced column dimensions allow reduction of the mobile phase flow rate to 0.4 mL min^{-1}

LC Coupling (Dionex) – As Species in Apple Juice

IC-ICP-MS for As Speciation

Column	Dionex AS-7 (2x250mm)
Mobile Phase	Gradient elution: 20 to 200 mM ammonium carbonate
Flow rate	0.3 mL min ⁻¹
Injection volume	20 µL

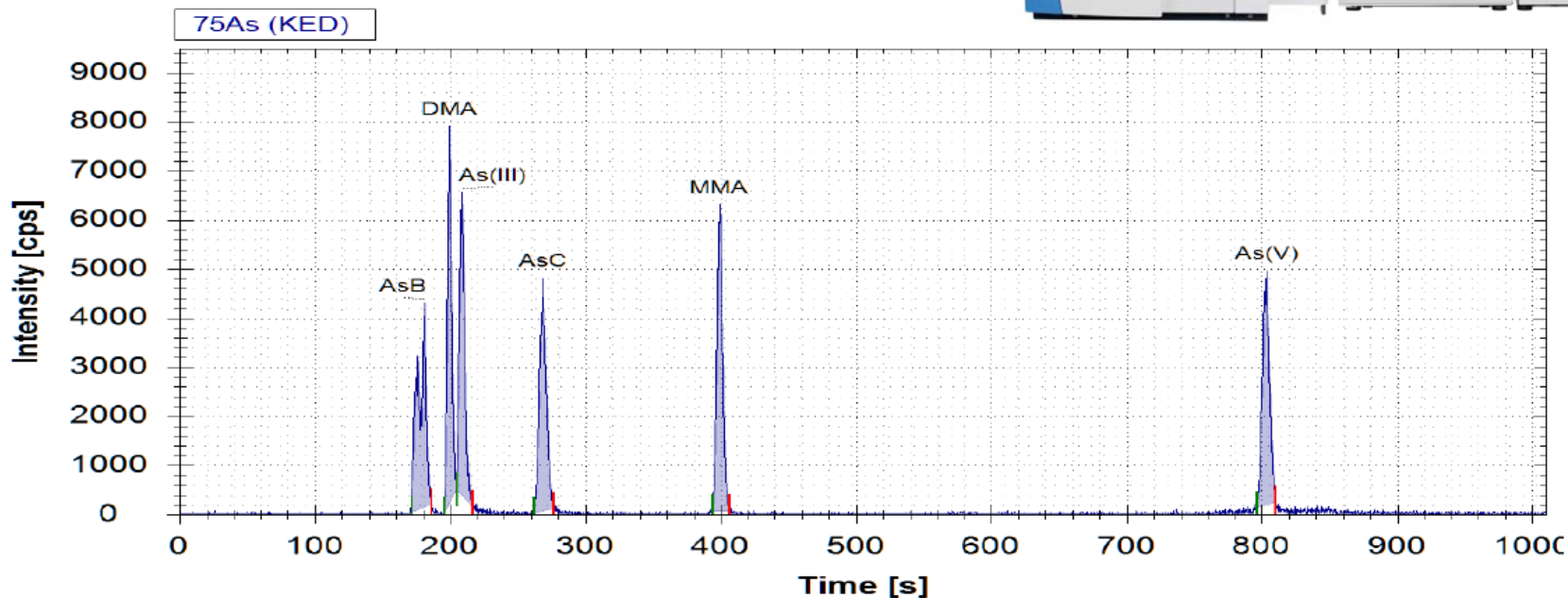

IC-ICP-MS for As Speciation

- 6 species detected
- ~7000 cps / ppb
- ~15 minute analysis
- Narrow peak shape improves S/N ratio (10 to 20s)
- Reproducibility < 4%
- Reduced solvent consumption without comprising separation efficiency

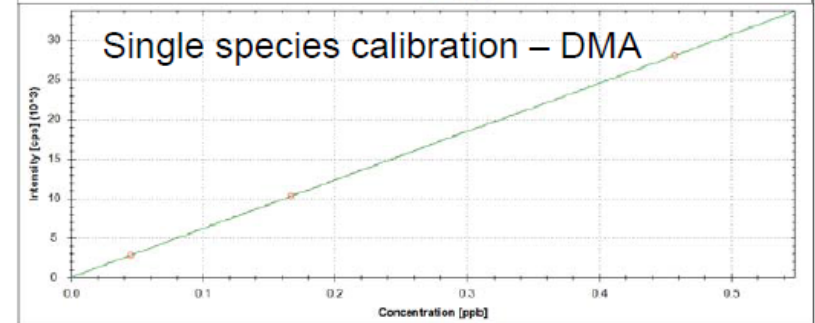
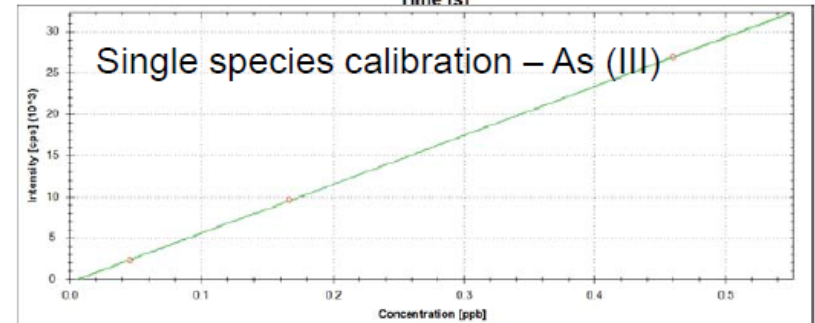
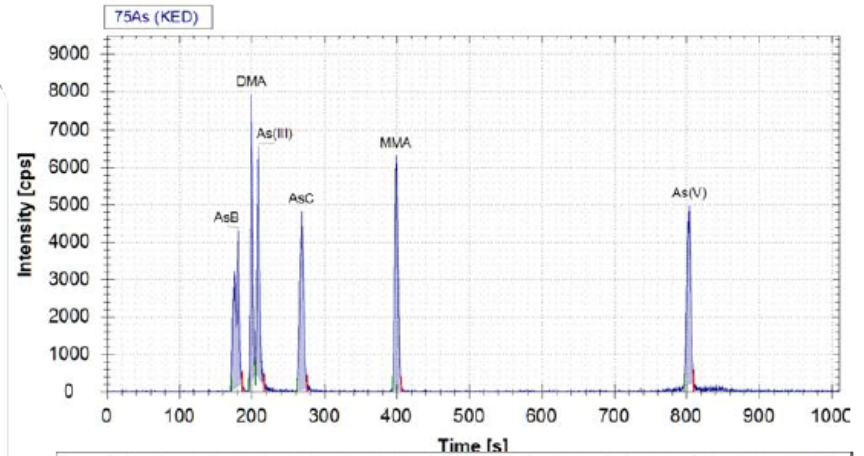

Arsenic Speciation Analysis of Apple Juice

- Low concentration of the individual species after dilution

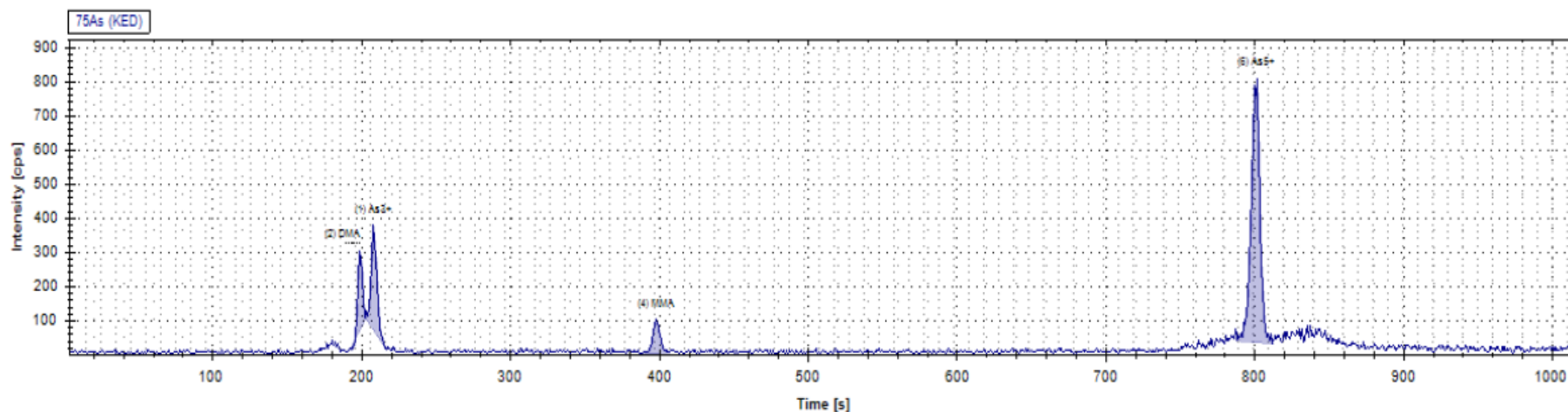

	DMA [ng g ⁻¹]	As (III) [ng g ⁻¹]	MMA [ng g ⁻¹]	As(V) [ng g ⁻¹]	Sum [ng g ⁻¹]	Total As [ng g ⁻¹]
Juice 3	-	0.5 ± 0.01	-	0.8 ± 0.01	1.3	1.7 ± 0.05
Juice 4	0.4 ± 0.05	0.3 ± 0.01	0.1 ± 0.05	0.7 ± 0.01	1.5	1.8 ± 0.05

- Method detection limits (MDL): 0.001 ng g⁻¹ As(V) to 0.011 ng g⁻¹ (MMA)

- Not detected

ICP-OES (iCAP 7000)

NEW



low cost
ICP-OES analysis

The Concept going forward



iCAP 6500

Fastest/Best Productivity, and flexibility through S/W plug-ins



iCAP 6300

Faster/More Productive for Routine QA/QC and easier to use



iCAP 6200

Entry level ICP – easier to use



Qtegra -
New
Common
Software
Platform

-
Easier to
use and
more plug-
ins for
advanced
flexibility

Thermo Scientific™ iCAP™ 7000 Series ICP-OES

- Nejúspěšnější ICP-OES na trhu, při zachování nejvyšší kvality dat
 - **iCAP 7200 ICP-OES** – základní úroveň, cenově efektivní investičně i provozně, vhodný do laboratoří s nižším počtem vzorků.
 - **iCAP 7400 ICP-OES** – Vhodný pro rutinní laboratoře, univerzální analytické aplikace, střední počet vzorků.
 - **iCAP 7600 ICP-OES** – Nejvyšší produktivita, maximální průchod vzorků, flexibilní podpora příslušenství jak např. LA..



iCAP 7200 (Dual)



iCAP 7000 Series – tři modely



- iCAP 7400
Radial nebo Dual



- iCAP 7600
Radial nebo Dual



Sprint valve system – How does it work?

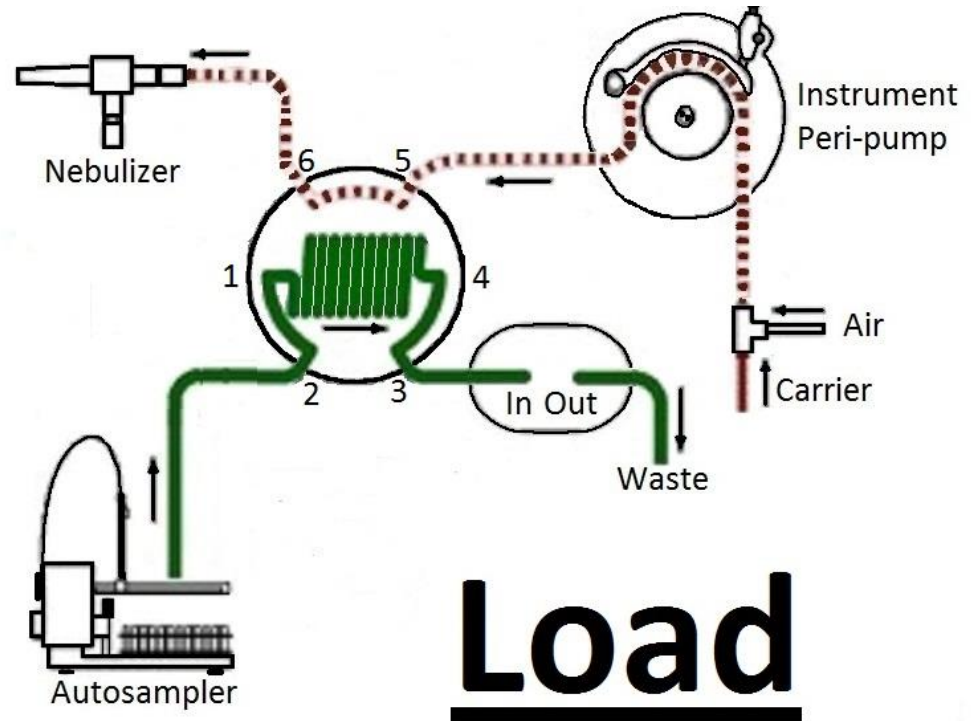

Sprint valve system – How does it work?

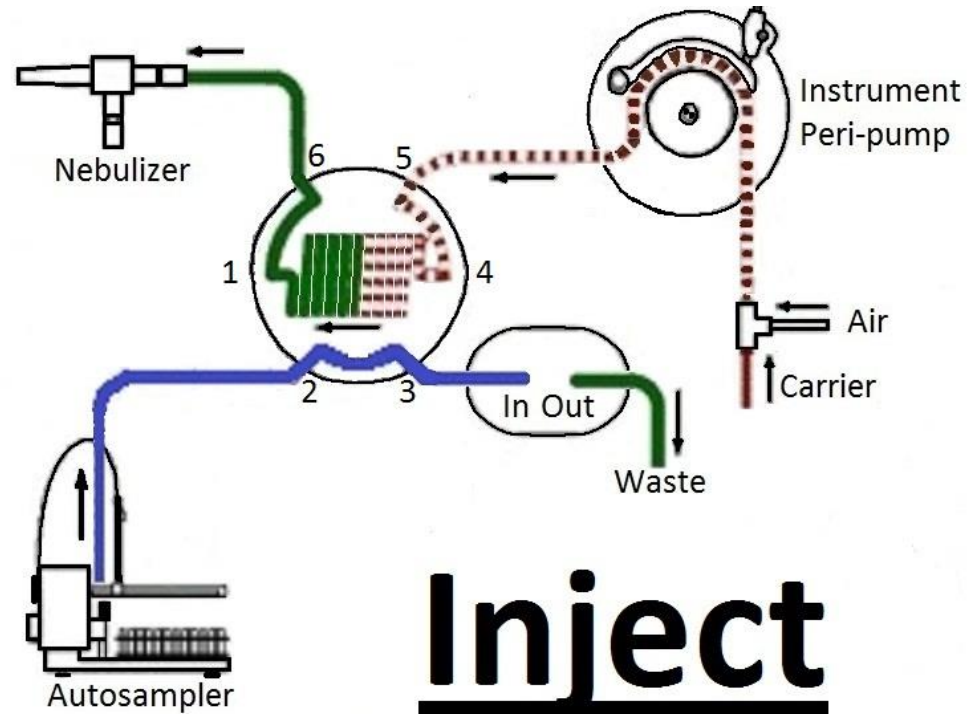

The iCAP 7000 Series ICP-OES Core Technologies

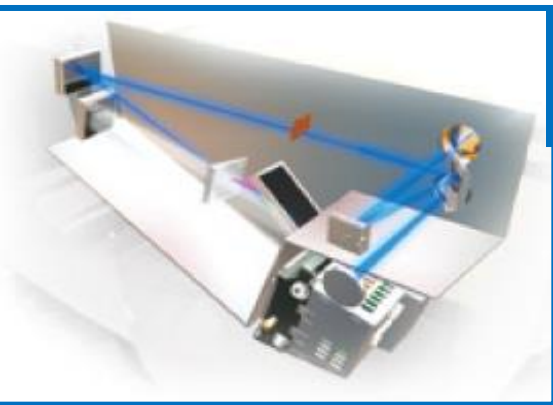

Optical design

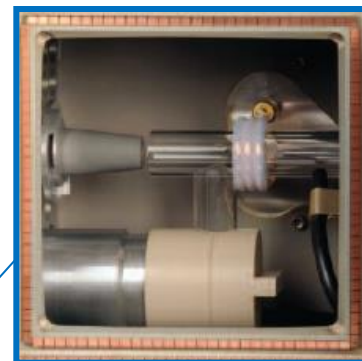

EMT torch & Duo viewing



Clip-in sample intro systems



Drain sensor

CID detector

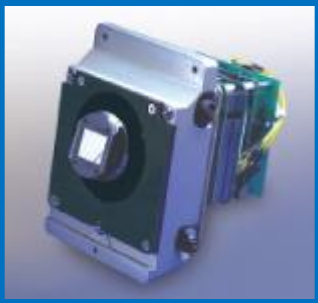

EMT Torch for Ease of Use for Routine Maintenance



TORCH ORIENTATION LOCK

- Auto alignment of the torch in the torch box
- Automatically establishes robust plasma gas connections



SCREW-THREADED CENTRE TUBE HOLDER

- Simple routine maintenance operations with the plasma on!

Still the best torch design and common ICP-OES/ICP-MS

Ceramic *D-Torch* Accessories – Key Features

- Fully demountable design for cost effective replacement of parts
- Identical geometry to EMT (parallel tube design for optimized gas flows and sample channel stability)
- Interchangeable with EMT design in any iCAP 7000 Series ICP
- Silicon nitride (Sialon) ceramic outer tube – highly durable material
- Alumina intermediate (auxiliary) tube – excellent chemical and temperature resistance
- Compatible with EMT centre tubes to enable maximum application flexibility



Dlouhodobá stabilita iCAP 7400

- Offers flexibility with the ability to have greater control of gas flows for method development of complex samples
 - Ideal for high salt samples
 - Ideal for organic samples
- Offers the benefits of MFC in terms of better long term stability
 - Ideal for long analytical runs

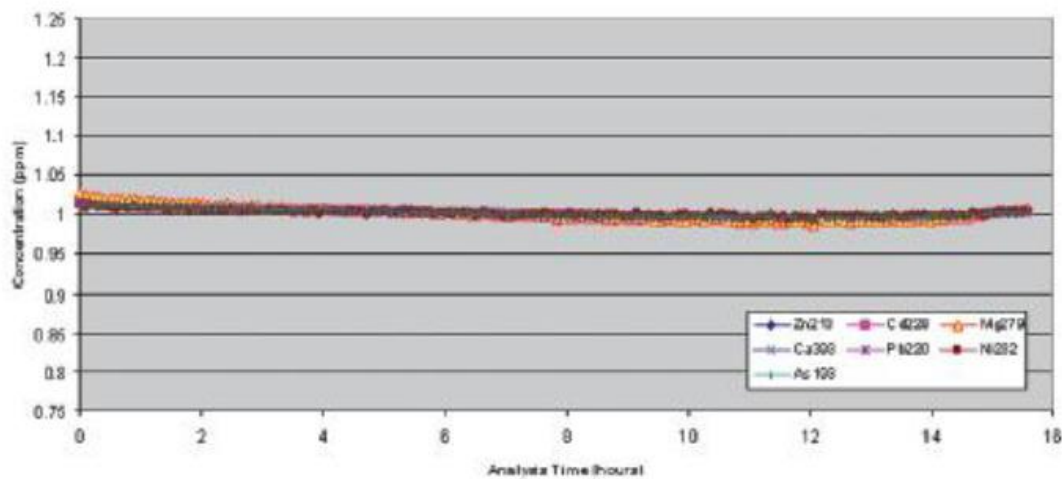

Heike Brandt, HPLC- ICP-AES-Kopplungen

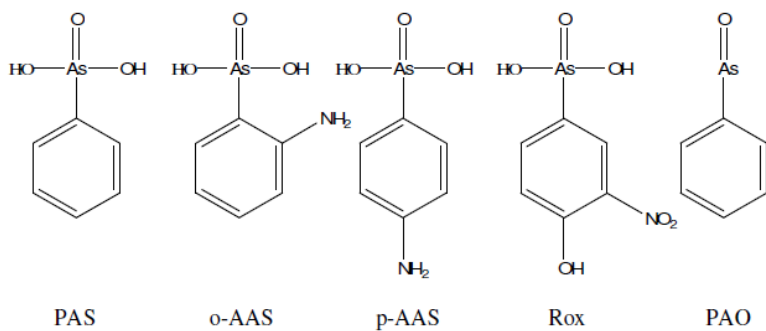
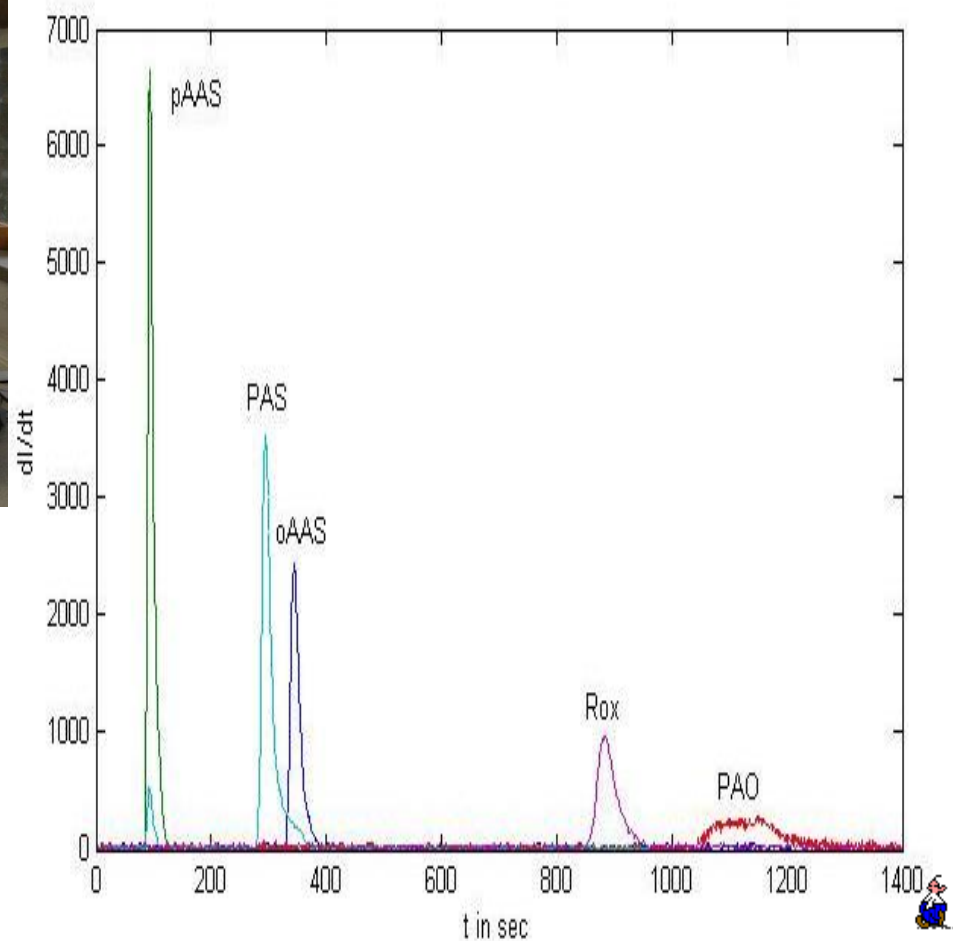

„Qtegra ISDS – a software platform“

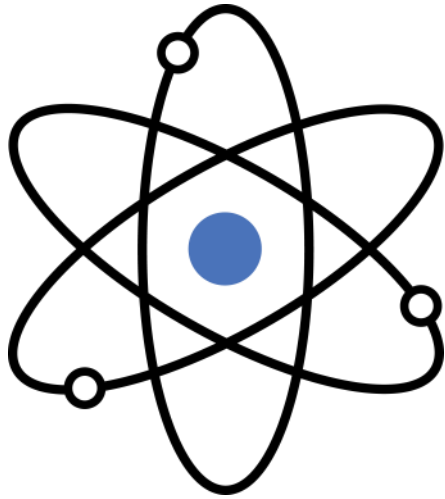

Elementy



a

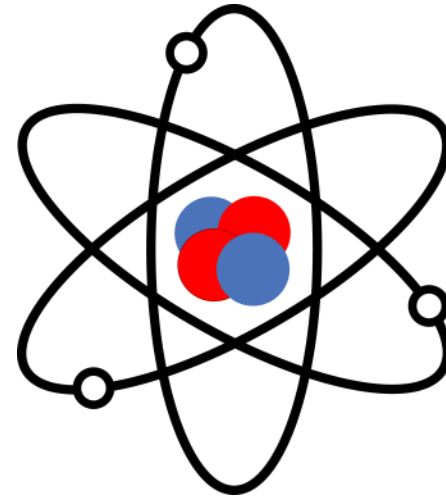

Isotopy

8 individuálních SW balíčků ...

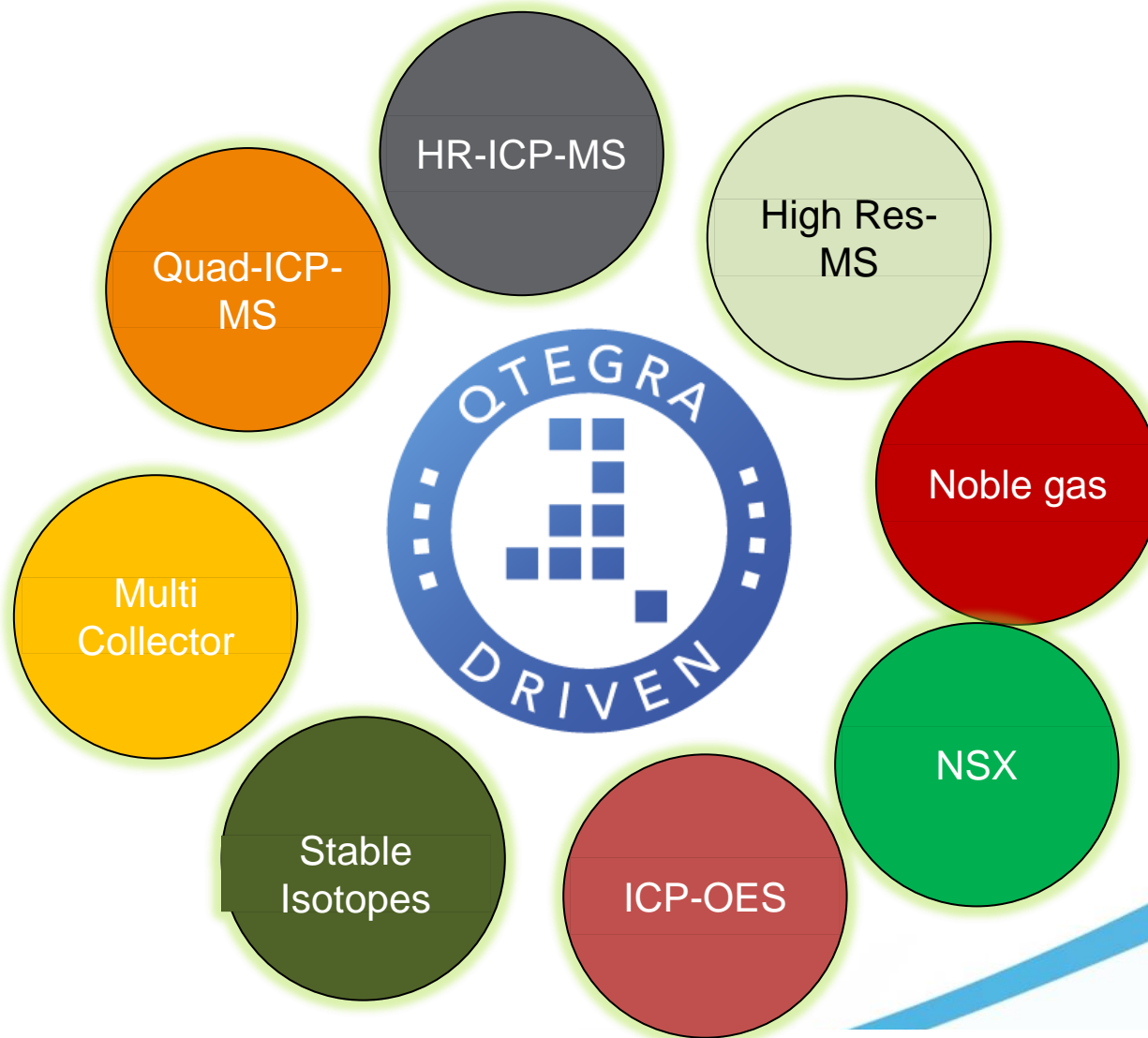

...jsou různé...

...ale v zásadě dělají totéž.

Qtegra v 1.5 Plug-Ins



Accela LC Autosampler



Accela LC Pump



iCAP Q



Cetac ASX-100



Cetac ASX-112FR



Cetac ASX-260



Cetac ASX-520



Chromleon



ESI SC-14DX



ESI SC-2DX



ESI SC-4DX



ESI SC-4S



PMI Analyte Laser Syst...



Cetac Laser



NWR Laser

Závěr

- Speciace je v současnosti rutinní metodologie poskytující dodatečné informace – nad rámec normální prvkové stopové analýzy
- Spojení ICP-MS s HPLC, IC nebo GC je významně zjednodušené a snadno použitelné
- Thermo Scientific je jediným výrobcem a poskytovatelem kompletního chromatografického řešení pokrývajícího většinu všech speciálních oblastí:

Kapalinová chromatografie

Iontová chromatografie

Plynová chromatografie

Ve spojení s:

Kvadrupólovým ICP-MS

Sektorovým HR-ICP-MS

Multikolektorovým HR-ICP-MS

Produktová linie TFS neponechává „mnoho“ volného prostoru pro detektory typu TOF, QqQ apod.

Plasma Robustness Test



Thermo Scientific iCAP family

Thermo Scientific iCAP Q ICP-MS a Thermo Scientific iCAP 6000/7000 Series ICP-OES



Děkují za pozornost

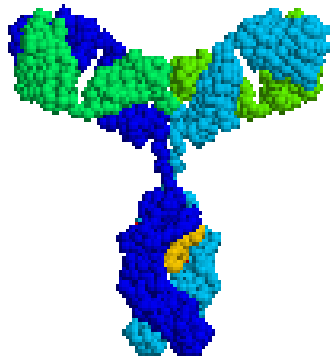

JANDERKA@PRAGOLAB.CZ