

Two-Dimensional HPLC Determination of Water-Soluble Vitamins in a Nutritional Drink

Dai Zhenyu,¹ Chen Jing,¹ Xu Qun,¹ and Jeffrey Rohrer²

¹Thermo Fisher Scientific, Shanghai, People's Republic of China;

²Thermo Fisher Scientific, Sunnyvale, CA, USA

Key Words

Food Analysis, Food Quality, Acclaim PolarAdvantage Column, Acclaim 120 C18 Column, Hypersil GOLD Phenyl Column

Goal

To develop an efficient high-performance liquid chromatography (HPLC) method for simple and sensitive determination of water-soluble vitamins in a complex multivitamin/mineral drink. Target analytes are B group vitamins, including thiamine (V_{B1}), riboflavin (V_{B2}), nicotinamide (V_{B3}), pantothenic acid (V_{B5}), pyridoxine (V_{B6}), biotin (V_{B7}), and cyanocobalamin (V_{B12}); and ascorbic acid (V_C).

Introduction

Vitamins are a well-known group of compounds that are essential for human health. They can be classified into two main groups: water- and fat-soluble. With the exception of V_{B6} and V_{B12} , water-soluble vitamins are not stored in the body. Thus, if one's dietary vitamin intake is insufficient, a vitamin supplement should be added to the diet.

The vitamin supplement can be in tablet form, a clear vitamin-enhanced functional drink, vitamin-enhanced milk, or a nontransparent multivitamin/mineral nutritional drink with additions of other substances (e.g., fruit extracts) that make it more complex than clear products. To ensure that these products contain the labeled amounts of vitamins, a number of reliable quality control assays are available.¹⁻³ For a vitamin tablet or a clear functional drink, the analysis is relatively simple and a routine HPLC method (e.g., a C18 column with UV detection) is satisfactory for quantifying the vitamins.⁴

Some samples, however, have too many additional components to allow a routine HPLC vitamin-quantification method. Vitamin-enhanced milk and a nontransparent multivitamin/mineral nutritional drink—referred to as a multivitamin nutritional drink throughout the rest of this study—are two such samples. In addition to vitamins, these samples also supply amino acids, minerals, coenzyme Q10, the compounds contained in grape extracts, and more. These additional compounds interfere with the separation of vitamins, making quantification difficult.



Therefore, a simple and sensitive two-dimensional HPLC (2D-HPLC) method is needed to quantify vitamins in these complex samples.

Equipment and Software

- Thermo Scientific™ Dionex™ UltiMate™ 3000 x2 Dual HPLC system, including:
 - DGP-3600RS Dual-Gradient Rapid Separation Pump System with SRD-3600 Integrated Solvent and Degasser Rack
 - WPS-3000TRS Rapid Separation Wellplate Sampler, Thermostatted, with a 100 μ L sample loop and a 100 μ L syringe
 - TCC-3000RS Rapid Separation Thermostatted Column Compartment equipped with two 2p–6p valves
 - DAD-3000RS Rapid Separation Diode Array Detector with 13 μ L flow cell
 - Mixer for 800 μ L Mixing Volume (P/N 6040.5750)
- Thermo Scientific™ Dionex™ Chromeleon™ Chromatography Data System (CDS) software version 7.1
- Thermo Scientific™ Orion™ 2-Star pH Benchtop Meter

Reagents and Standards

- Deionized (DI) water, 18.2 M Ω -cm resistivity
- Acetonitrile (CH₃CN) for HPLC (Fisher Scientific P/N AC610010040)
- Potassium Phosphate Monobasic (KH₂PO₄) (Fisher Scientific P/N P286-1)
- o-Phosphoric Acid (H₃PO₄), 85%, (Fisher Scientific P/N A260-500)
- Products from the National Institute for the Control of Pharmaceutical and Biological Products, Beijing, China:
 - V_{B1} – V_{B3} – V_{B6} – V_{B12}
 - V_{B2} – V_{B5} – V_{B7} – V_C

Preparation of Standard Solutions

To prepare water-soluble vitamin standards of V_{B1}, V_{B3}, V_{B5}, V_{B6}, V_{B7}, V_{B12}, and V_C, weigh 10 mg of the vitamin powder and add DI water to 10 mL in a volumetric flask to make stock solutions of 1.0 mg/mL for each vitamin. Make a fresh preparation of V_C, due to its limited stability. Also, because of the limited solubility of V_{B2} in water, decrease the concentration of the V_{B2} stock solution to 0.03 mg/mL. Weigh 3 mg of V_{B2} into 100 mL DI water to address the solubility issue. If a 10 mL volumetric flask were used, 0.3 mg of V_{B2} would have to be weighed, but that would exceed the precision range of the balance.

Add 500 μ L of V_{B2} stock solution, 100 μ L each of V_{B5} and V_{B7} stock solutions, and 50 μ L each of V_{B1}, V_{B3}, V_{B6}, V_{B12}, and V_C stock solutions to a 1 mL sample vial. Bring the final volume to 1 mL by adding 50 μ L of DI water to make the mixed stock standard solution. In this mixed stock standard solution, the concentration of V_{B2} will be 15 μ g/mL, the concentrations of V_{B5} and V_{B7} will be 100 μ g/mL, and the concentration of the other vitamins will be 50 μ g/mL.

For the preparation of mixed working standard solutions for calibration, add the appropriate volume of the mixed stock standard solution into 10 mL glass vials and bring to 10 mL with DI water. See Table 1 for details.

Sample Preparation

A multivitamin nutritional drink supplemented with V_{B1}, V_{B2}, V_{B3}, V_{B5}, V_{B6}, V_{B7}, V_{B12}, and V_C was provided by a customer. The drink also contained some fat-soluble vitamins, minerals, amino acid complex, grape seed extract, coenzyme Q10, and other ingredients added to meet daily nutritional needs. Table 2 lists the sample components.

Dilute the drink sample with DI water if necessary and filter through a 0.45 μ m filter. To determine if the sample needs to be diluted, compare the labeled values to the calibration ranges in this study. Store the sample in a brown bottle at 4 $^{\circ}$ C before analysis.

Table 1. Preparation of mixed working standard solutions of water-soluble vitamins.

Mixed Working Standard Solution		1	2	3	4	5	6
Volume of Mixed Stock Standard Solution for a 10 mL Preparation (mL)		0.02	0.1	0.2	1.0	2.0	10
Concentration of Each Vitamin (mg/L)	V _{B2}	0.03	0.15	0.3	1.5	3.0	15
	V _{B5} , V _{B7}	0.2	1.0	2.0	10	20	100
	V _{B1} , V _{B3} , V _{B6} , V _{B12} , V _C	0.1	0.5	1.0	5.0	10	50

Table 2. Labeled values of the multivitamin nutritional drink.

Ingredient	Amount Per Serving*	Ingredient	Amount Per Serving
Total Carbohydrate	9 g	Zinc (as gluconate)	15 mg
Vitamin A	10000 IU	Selenium (as L-selenium methione)	100 mcg
Vitamin C	1000 mg	Copper (as gluconate)	1 mg
Vitamin D3	200 IU	Manganese (as gluconate)	5 mg
Vitamin E	200 IU	Chromium (as amino acid chelate)	200 mcg
Vitamin K1	300 mcg	Potassium (as citrate)	100 mg
Vitamin B1	30 mg	Choline (as bitartrate)	30 mg
Vitamin B2	30 mg	Inositol	30 mg
Vitamin B3	30 mg	Boron (as amino acid chelate)	1 mg
Vitamin B5	150 mg	Amino Acid Complex (proprietary formula)	125 mg
Vitamin B6	30 mg	Grape Seed Extract	25 mg
Vitamin B7	300 mcg	Coenzyme Q-10	5 mg
Vitamin B12	500 mcg	Dimethyl Glycine	25 mg
Folate	400 mcg	Paba	30 mg
Calcium	600 mg	Citrus Bioflavonoids	13 mg
Phosphorus	80 mg	Glucolactone	150 mg
Iron (as gluconate)	4 mg	Plant-Derived Minerals	600 mg
Magnesium (as citrate, gluconate)	300 mg		

* Serving size: 1 fluid oz

Table 3. Gradient program and valve switching.

First Dimension (Right Pump)				Valve Switching			Second Dimension (Left Pump)			
Time (min)	Flow Rate (mL/min)	% A (25 mM Phosphate Buffer, pH 3.0)	% B (CH ₃ CN)	Time (min)	Right Valve Position	Left Valve Position	Time (min)	Flow Rate (mL/min)	% A (25 mM Phosphate Buffer, pH 3.0)	% B (CH ₃ CN)
0	0.8	100	0	0	6_1	1_2	0	0.8	100	0
14	0.8	100	0	3.94	1_2	6_1	5	0.8	100	0
23.5	0.8	50	50	4.3	6_1	1_2	12.5	0.8	65.0	35.0
24	0.8	0	0	5.32	1_2	6_1	13.0	0.8	20.0	80.0
30	0.8	0	0	5.89	6_1	1_2	21.0	0.8	20.0	80.0
—	—	—	—	7.8	1_2	1_2	21.5	0.8	100	0
—	—	—	—	8.35	6_1	6_1	30	0.8	100	0
—	—	—	—	13.12	1_2	1_2	—	—	—	—
—	—	—	—	13.28	6_1	6_1	—	—	—	—
—	—	—	—	14.61	1_2	1_2	—	—	—	—
—	—	—	—	14.82	6_1	6_1	—	—	—	—
—	—	—	—	15.42	1_2	1_2	—	—	—	—
—	—	—	—	15.60	6_1	6_1	—	—	—	—
—	—	—	—	15.97	1_2	1_2	—	—	—	—
—	—	—	—	16.12	6_1	6_1	—	—	—	—
—	—	—	—	28.5	6_1	1_2	—	—	—	—

Conditions

First Dimension

Columns: For water-soluble vitamins except for V_{B12}, Thermo Scientific™ Acclaim™ PolarAdvantage™ (PA), 5 μm Analytical, 4.6 × 250 mm (P/N 061321)

For V_{B12}, Thermo Scientific™ Hypersil GOLD™ Phenyl Analytical HPLC, 5 μm, 4.6 × 150 mm (P/N 25905-154630)

Mobile Phase: A. 25 mM phosphate buffer (dissolve ~3.4 g KH₂PO₄ in 1 L water and adjust the pH to 3.0 with H₃PO₄)
B. CH₃CN

Gradient: See Table 3

Flow Rate: 0.8 mL/min

Inj. Volume: 10 μL

Temperature: 25 °C

Detection: UV, absorbance at 210 and 254 nm

Second Dimension

Column: Acclaim 120 C18, 5 μm Analytical, 4.6 × 150 mm (P/N 059148)

Mobile Phase: Same as used in the First Dimension

Flow Rate: 0.8 mL/min

Temperature: 25 °C

Detection: UV absorbance at 210, 245, 268, and 291 nm

These conditions apply to Figures 3 through 7.

Results and Discussion

Conventional HPLC Method for the Determination of Vitamins

Currently, there is no U.S. Pharmacopeia (USP) method for the separation of a mixture of all eight water-soluble vitamins. A USP method for individual vitamins is complicated (i.e., sodium perchlorate, phosphoric acid, dimethyl sulfoxide, acetonitrile, and water are needed for biotin determination) and involves an ion-pairing agent to retain hydrophilic vitamins.⁵ Due to the irreversible impact of the ion-pairing agent on column performance, extensive research was conducted to search for methods without ion-pairing agents, and this for a simpler mobile phase.

Recently, acidic or neutral phosphate buffer/organic solvent mobile phases have been used to separate vitamins in an extract of a multivitamin tablet and in vitamin-enhanced functional drinks that are less complex than the one investigated here.¹ For complex samples such as certain multivitamin nutritional drinks, the additional supplements can interfere with vitamin separation and, ultimately, their detection by UV absorbance. Figure 1 shows that use of a typical HPLC method for a multivitamin nutritional drink results in the water-soluble vitamin peaks being hard or even impossible to quantify due to the large number of UV-absorbing interfering peaks. Obviously, Peaks 1–3 cannot be quantified. Peaks 5–8 can be detected in the sample, but due to all the additional peaks, the vitamin peaks cannot be precisely quantified. Comparison of the UV spectra of the standard and the sample confirmed that Peaks 5–8 were not pure enough for quantification.

The 2D-HPLC Method

Two-dimensional HPLC has been used to achieve efficient separation of complex samples. Not only do two columns with different chemistries provide additional separation power, but use of heart-cutting technology in on-line 2D-HPLC also simplifies the separation in the second dimension. The work shown here uses 2D chromatography to determine water-soluble vitamins in a complex sample.

Figure 2 shows the configuration of the 2D-HPLC system used for this study. After simple sample preparation (filter the sample, then dilute with DI water if necessary), inject the sample into the first dimension and partially separate it using an Acclaim PA column. The in-line UV detector determines where the water-soluble vitamins elute. An injection of the mixed standard determines the start and end times for each vitamin peak. Use these values to switch the valves.

Switch the right valve to the 1_2 position to individually transfer the vitamin peaks to the flow path of the second column. For early eluting vitamin peaks, switch the left valve to the 1_6 position so that these vitamin fractions

Column: Acclaim PA1, 5 μ m Analytical, 4.6 \times 250 mm
 Mobile Phase: A. 25 mM phosphate buffer (dissolve ~3.4 g KH_2PO_4 in 1 L water and adjust pH to 3.0 with H_3PO_4)
 B. CH_3CN
 Gradient: CH_3CN , 0–14 min, 0%; 14–23.5 min, 0–50%; 23.5–24 min, 50–0%
 Flow Rate: 0.8 mL/min
 Inj. Volume: 10 μ L
 Temperature: 25 $^\circ\text{C}$
 Detection: UV absorbance at 210 nm
 Samples: A. Standard mixture B. Multivitamin nutritional drink

Peaks: 1. V_{B1} 50 mg/L 5. V_{B5} 100
 2. V_C 50 6. V_{B12} 50
 3. V_{B3} 50 7. V_{B2} 15
 4. V_{B6} 50 8. V_{B7} 100

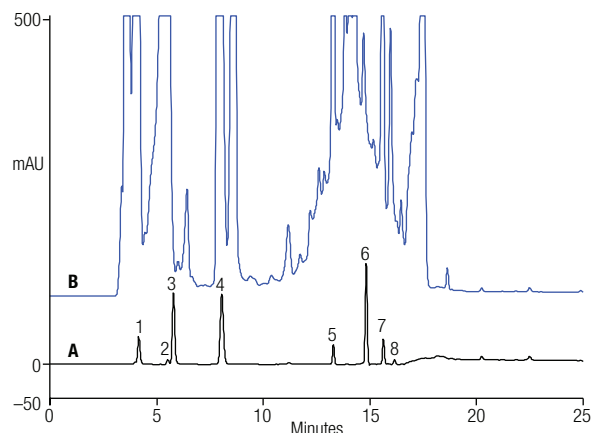

Figure 1. A standard mixture (A) and a multivitamin nutritional drink sample (B) using a conventional HPLC method.

are directly transferred to the second column. For late eluting vitamin peaks, switch the left valve to the 1_2 position to put the 750 μ L mixer in line. In this configuration, the water mobile phase in the second dimension will dilute the acetonitrile from the first-dimension mobile phase. This enables the second-dimension column to trap the vitamin peaks.

Note: When the right valve is switched to the 1_2 position, UV Detector 1 will be connected between the two columns. However, the backpressure of the second-dimension column may exceed the pressure limit of the UV Detector 1 flow cell. Thus, choose the proper particle size and length of the second-dimension column to keep the backpressure below the pressure limit of the flow cell. The pressure limit command in the instrument method can also be set to stop the flow in any situation when backpressure may become too high.

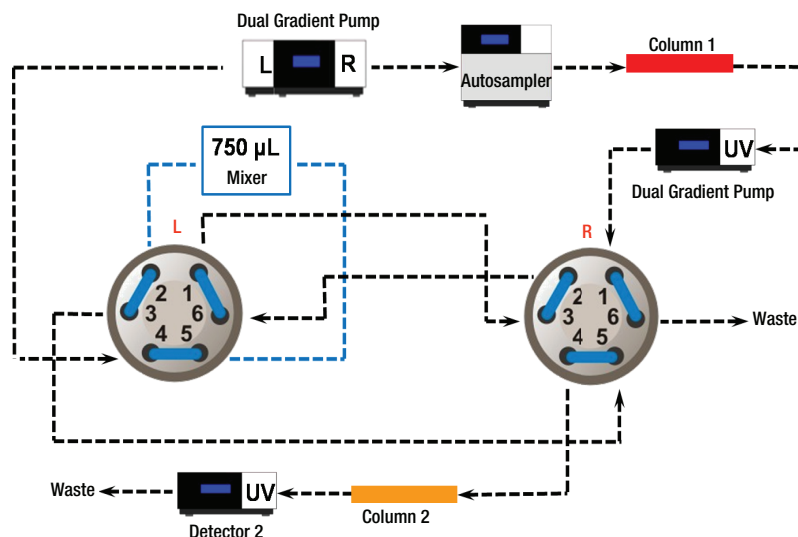

Figure 2. Configuration of the 2D-HPLC system.

Development of the 2D-HPLC Method

Valve switching

To achieve optimal resolution and peak shape in 2D-HPLC applications, the critical part of method development is the transfer of first-dimension peaks to the second-dimension column. Ideally, the first-dimension mobile phase being cut and transferred with target peaks to the second dimension will be same as the second-dimension mobile phase at the time of transfer. But in reality, the two mobile phases usually will have different concentrations of acetonitrile or other organic solvent.

Figure 3, Chromatogram A shows that Peaks 5, 7, and 8 disappear when they are directly transferred to the second dimension. Obviously, the late eluting peaks from the first column are contained in too high a concentration of acetonitrile to be retained on the second column. The traditional approach to this problem is to provide water to dilute the acetonitrile in the transferred fraction with a tertiary pump so the fraction can be retained on the trap column ahead of the second column.⁶ However, the need for an additional pump limits this application.

Thermo Scientific Application Note (AN) 1023 demonstrated an alternative way to solve this problem.⁷ Briefly, a 750 μ L mixer was configured in line before the eluted fraction was transferred to the second dimension. Then the peak mobile phase was mixed extensively with the second-dimension starting mobile phase (water phase) before the second-dimension separation.

In this study, the authors initially applied the AN 1023 approach for all target peaks. It worked well for late eluting peaks, which had high concentrations of acetonitrile, but the early eluting peaks broadened (Figure 3, Chromatogram B). After conducting additional experiments, the authors discovered that early eluting vitamin peaks broadened due to their physiochemical characteristics. These peaks cannot be trapped at the head of the second column, even with a 100% water mobile phase. Thus, the configuration was modified so that early eluting peaks are directly transferred to the second column, whereas late eluting peaks are transferred into the 750 μ L mixer before the second column. Figure 3, Chromatogram C shows that the final configuration works well for all eight water-soluble vitamins.

Detection: UV absorbance at 210 nm
 Valve Position: See Table 3
 Configurations: A. 750 μ L mixer always off-line
 B. 750 μ L mixer always in-line
 C. 750 μ L mixer off-line for Peaks 1–3, in-line for Peaks 4–8

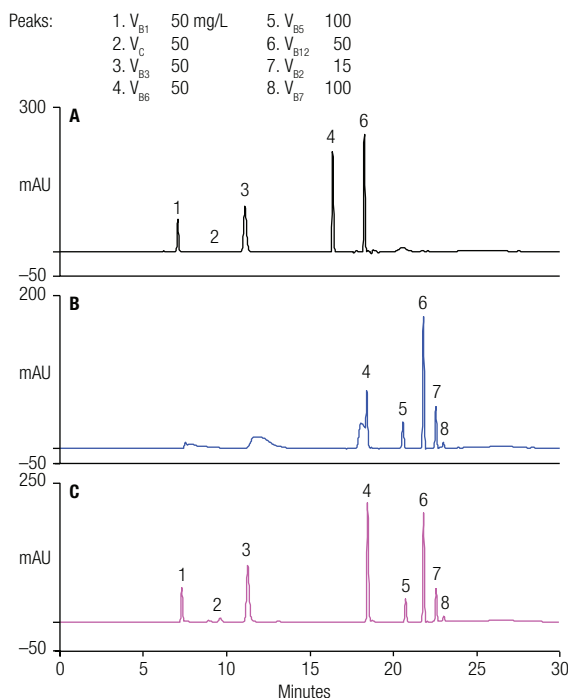

Figure 3. Second-dimension analysis of the standard mixture with three different configurations.

Choice of wavelength for the UV detector

Vitamins B₁, B₂, B₆, and C were detected at 245, 268, 291, and 245 nm, respectively, which are the wavelengths of maximum UV absorbance of each. Vitamin B₃ was detected at 268 nm, which is close to its maximum UV absorbance. The maximum UV absorbance wavelengths of V_{B5} and V_{B7} are below 200 nm; therefore, to minimize noise, both were detected at 210 nm. Vitamin B₁₂ was detected with the 245 nm channel. If desired, a fifth channel of 361 nm can be configured to detect V_{B12} at its absorbance maximum.

Column choice and its impact on separation

Several combinations of columns were tested. Previous work suggested that good choices for most water-soluble vitamins are an Acclaim PA column used as the first-dimension column and an Acclaim 120 C18 column used as the second-dimension column.⁸ Most water-soluble vitamins can be separated with good resolution using this column combination, but V_{B12} coelutes with an impurity in the drink sample, making quantification of V_{B12} impossible.

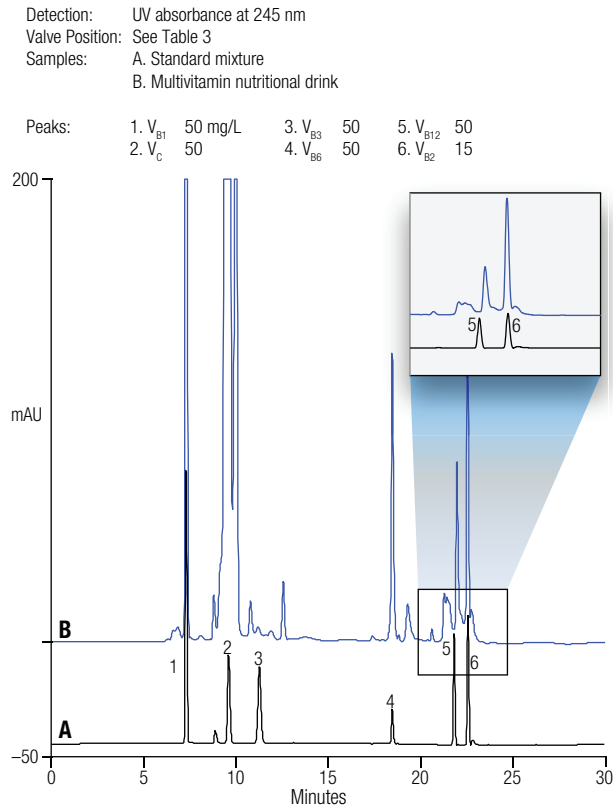

Figure 4. A standard mixture (A) and a multivitamin nutritional drink sample (B) using an Acclaim PA column in the first dimension.

The authors searched for another column to use for the first dimension. The Hypersil GOLD Phenyl column worked well for this purpose. Figure 4 shows that V_{B12} was not detected at 245 nm when an Acclaim PA column was used in the first dimension. However, when the Hypersil GOLD Phenyl column was used in the first dimension, V_{B12} was detected (Figure 5). The authenticity of the V_{B12} peak was confirmed by its UV spectrum.

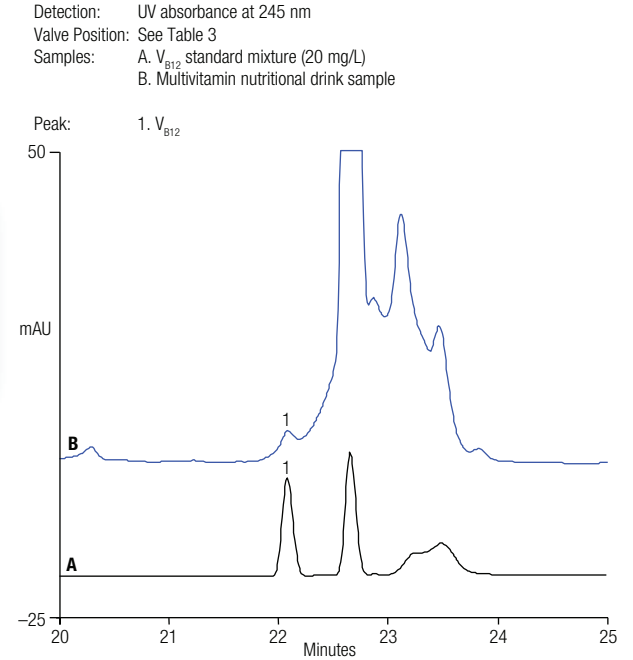

Figure 5. A V_{B12} standard (A) and a multivitamin nutritional drink sample (B) using a Hypersil GOLD Phenyl column in the first dimension.

Table 4. Reproducibility of retention time and peak area for water-soluble vitamins.

Water-Soluble Vitamin	Retention Time RSD	Peak Area RSD
V _{B1}	0.05	1.08
V _{B2}	0.02	0.32
V _{B3}	0.11	0.62
V _{B5}	0.03	0.36
V _{B6}	0.03	0.45
V _{B7}	0.02	0.87
V _{B12}	0.02	0.48
V _C	0.1	3.44

Reproducibility, Linearity, and Detection Limits

Prior to sample analysis, reproducibility was estimated by making eight replicate injections of water-soluble vitamins. The RSDs for retention time and peak area are shown in Table 4. An overlay of the eight injections is shown in Figure 6.

Calibration linearity for the water-soluble vitamins was investigated by making three replicate injections of a mixed standard prepared at five or six different concentrations. The external standard method was used to calculate the calibration curve and quantify these compounds in samples. Table 5 reports the data from the calibration as calculated by Chromeleon CDS software. The authors found linear calibration curves for each vitamin over the ranges evaluated. The single-sided Student's *t* test method was used for estimating method detection limits (MDL). These data are reported in Table 5.

Detection: UV absorbance at 210 nm
Valve Position: See Table 3
Samples: A_H, consecutive injections 1–8

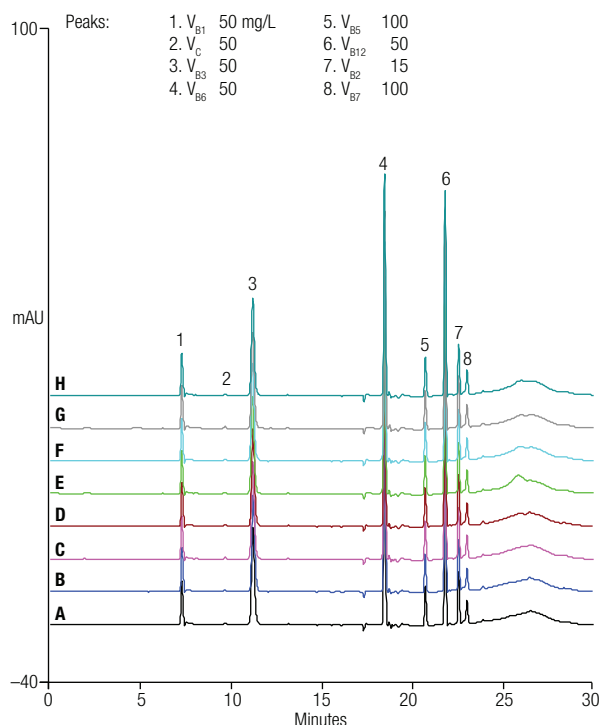

Figure 6. Chromatogram overlays of eight consecutive injections of a mixture of water-soluble vitamin standards.

Sample Analysis

Vitamins B₇ and B₁₂ were not detected in the multivitamin nutritional drink, possibly due to their low concentration in the sample. Vitamin B₃ was surprisingly not detected. Vitamin B₃ was fully recovered when spiked into the sample at its labeled value; therefore, the method is capable of determining V_{B3}. The other water-soluble vitamins were detected close to their labeled values.

Table 5. Calibration data and MDLs for the water-soluble vitamins.

Water-Soluble Vitamin	Detection Wavelength (nm)	Range (µg/mL)	Regression Equation	r	MDL (µg/mL)
V _{B1}	245	0.5–10	A=0.1755c-0.1080	0.9978	0.30
V _{B3}	268	0.5–50	A=0.2385c+0.0276	0.9999	0.23
V _{B6}	291	0.5–50	A=0.2918c+0.1237	0.9999	0.18
V _{B5}	210	1.0–100	A=0.0462c+0.0161	0.9999	0.26
V _{B12}	245	0.5–50	A=0.1026c+0.0153	0.9999	0.20
V _{B2}	268	0.15–15	A=0.9618c-0.0423	0.9995	0.03
V _{B7}	210	2.0–100	A=0.0101c	0.9994	1.5
V _C	245	—	—	—	—

Although V_C in the working standard solutions is quite unstable, its presence in the multivitamin nutritional drink appeared to be relatively stable. As shown in Figure 7, V_C is a major peak in the sample chromatogram. Good recoveries of water-soluble vitamins in the spiked sample (Table 6) provided another positive indicator of method accuracy. This 2D-HPLC method greatly simplifies the second-dimension chromatogram, as shown in Figure 7.

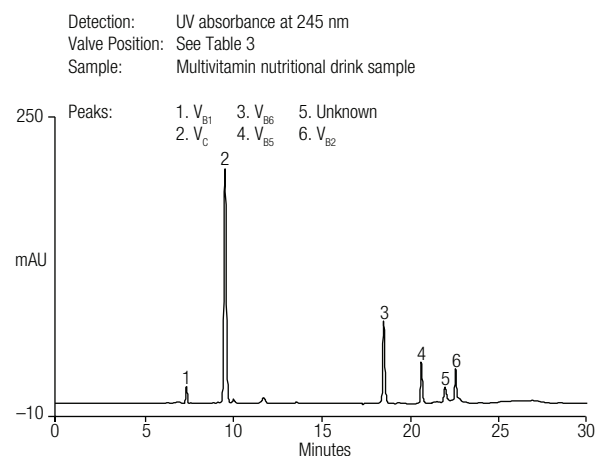

Figure 7. Second dimension of multivitamin nutritional drink sample (100-fold dilution).

Conclusion

Two-dimensional HPLC simplifies the determination of the vitamin content of a multivitamin nutritional drink, a complex sample. Analysis of this complex sample requires only off-line filtration because the remainder of the sample preparation is automated by the UltiMate 3000 x2 Dual HPLC system and Chromeleon CDS software.

References

- Dionex (now part of Thermo Scientific) Application Note 251: Determination of Water- and Fat-Soluble Vitamins in Nutritional Supplements by HPLC with UV Detection. Sunnyvale, CA, 2010. [Online] www.dionex.com/en-us/webdocs/87181-AN251-HPLC-vitamin-supplements-25June2010-LPN2533.pdf (accessed Oct. 24, 2013).
- Moreno, P.; Salvado, V. Determination of Eight Water- and Fat-Soluble Vitamins in Multivitamin Pharmaceutical Formulations by High-Performance Liquid Chromatography. *J. Chromatogr., A* 2000, 870, 207–215.
- Perveen, S.; Yasmin, A; Khan, K.M. Quantitative Simultaneous Estimation of Water Soluble Vitamins, Riboflavin, Pyridoxine, Cyanocobalamin and Folic Acid in Nutraceutical Products by HPLC. *The Open Analytical Chemistry Journal* 2009, 3, 1–5.

Table 6. Analysis results of water-soluble vitamins in the multivitamin nutritional drink sample.

Analyte	Labeled (mg/mL)*	Detected ($\mu\text{g/mL}$)	Added ($\mu\text{g/mL}$)	Found ($\mu\text{g/mL}$)	Recovery (%)
V_{B1}	1	1.03	1	1.98	95
V_{B3}	1	ND	1	0.96	96
V_{B6}	1	1.1	1	2.2	110
V_{B5}	5	4.51	2	6.03	76
V_{B12}	0.015	ND	1	0.83	83
V_{B2}	1	1.03	0.3	1.34	103
V_{B7}	0.01	ND	2	2.30	115
V_C	35	Detected	—	—	—

*The sample is diluted 1000 times before analysis; thus, 1 mg/mL will be detected as 1 $\mu\text{g/mL}$. ND = not detected.

- Dionex (now part of Thermo Scientific) Application Note 216: Determination of Water- and Fat-Soluble Vitamins in Functional Waters by HPLC with UV-PDA Detection. Sunnyvale, CA, 2009. [Online] www.dionex.com/en-us/webdocs/71938-AN216-HPLC-Vitamins-FunctionalWaters-30April09-LPN2145.pdf (accessed Oct. 24, 2013).
- Vitamins/Dietary Supplements*, The U.S. Pharmacopeia 35, NF 30, Washington, DC, 2008, pp 1592–1605.
- Dionex (now part of Thermo Scientific) Application Note 287: Two-Dimensional HPLC Combined with On-Line SPE for Determination of Sudan Dyes I–IV in Chili Oil. Sunnyvale, CA, 2011. [Online] www.dionex.com/en-us/webdocs/111142-AN287-HPLC-Sudan-Dyes-Chili-Oil-21Sept2011-LPN2919.pdf (accessed Oct. 24, 2013).
- Thermo Scientific Application Note 1023: Determination of Sudan Dyes I–IV in Curry Paste. Sunnyvale, CA, 2012. [Online] www.dionex.com/en-us/webdocs/113854-AN1023-LC-2D-Sudan-Dyes-Curry-Paste-AN70212_E.pdf (accessed Oct. 24, 2013).
- Dionex (now part of Thermo Scientific) Technical Note 89: Determination of Water- and Fat-Soluble Vitamins by HPLC. Sunnyvale, CA, 2010. [Online] www.dionex.com/en-us/webdocs/88784-TN89-HPLC-WaterFatSolubleVitamins-27Oct2010-LPN2598.pdf (accessed Oct. 24, 2013).

www.thermoscientific.com/dionex

©2013 Thermo Fisher Scientific Inc. All rights reserved. ISO is a trademark of the International Standards Organization. All other trademarks are the property of Thermo Fisher Scientific Inc. and its subsidiaries. This information is presented as an example of the capabilities of Thermo Fisher Scientific Inc. products. It is not intended to encourage use of these products in any manners that might infringe the intellectual property rights of others. Specifications, terms and pricing are subject to change. Not all products are available in all countries. Please consult your local sales representative for details.



Thermo Fisher Scientific, Sunnyvale, CA
USA is ISO 9001:2008 Certified.

Africa +43 1 333 50 34 0
Australia +61 3 9757 4300
Austria +43 810 282 206
Belgium +32 53 73 42 41
Brazil +55 11 3731 5140
Canada +1 800 530 8447
China 800 810 5118 (free call domestic)
400 650 5118

Denmark +45 70 23 62 60
Europe Other +43 1 333 50 34 0
Finland +358 9 3291 0200
France +33 1 60 92 48 00
Germany +49 6103 408 1014
India +91 22 6742 9494
Italy +39 02 950 591

Japan +81 6 6885 1213
Korea +82 2 3420 8600
Latin America +1 561 688 8700
Middle East +43 1 333 50 34 0
Netherlands +31 76 579 55 55
New Zealand +64 9 980 6700
Norway +46 8 556 468 00

Russia/CIS +43 1 333 50 34 0
Singapore +65 6289 1190
Sweden +46 8 556 468 00
Switzerland +41 61 716 77 00
Taiwan +886 2 8751 6655
UK/Ireland +44 1442 233555
USA +1 800 532 4752
AN70755_E 01/14S

Thermo
SCIENTIFIC

Part of Thermo Fisher Scientific